



Advanced Digital Trainer

EXPERIMENTS

Volume 5

PART NO. 2766-00-321

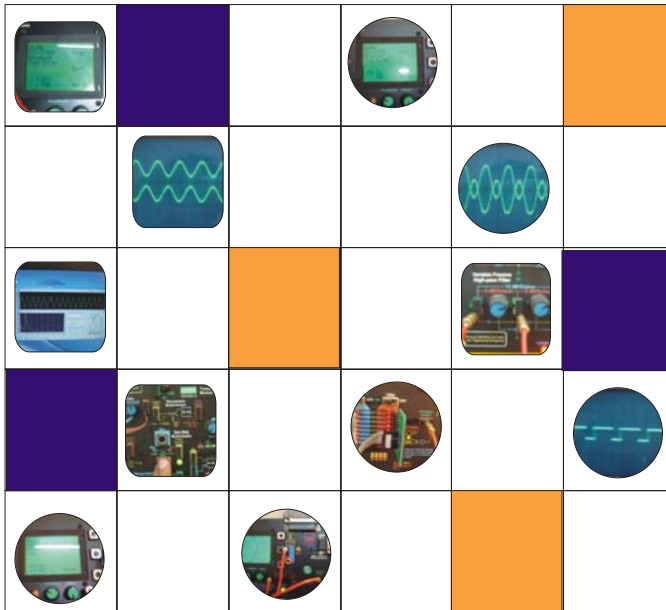

**COMPREHENSIVE AND ILLUSTRATED
EASY EXPERIMENTS STARTUP
LAB MANUAL**

THANK YOU FOR CHOOSING RIMS EDUCATION PRODUCTS AND SERVICES

Once you have made it through this guide, you will have a firm grip on your lab experiments and operations of the RIMS product you are using. How to get your training equipment operational, basic maintenance and setting up desired experiments will just be a breeze. Everything you need for a quick and easy start is presented here—useful hints and tips makes it simple to conduct your lab and hands-on training sessions. We are happy that you have joined our vast community of over 30 thousand valued users, which grow as we bring you the latest technology at most competitive prices. We value your business and hope that you will enjoy being an important member of the RIMS Education Community.

Customer Support Team



EU, USA and Canada

Weston Villa, 37 Wolsey Road, Esher, Surrey
United Kingdom KT10 8NT
www.rims-tech.co.uk

Middle East & Asia Pacific

632-B Chakala Scheme-III Rawalpindi
Pakistan 46000
www.rimsedu.com

© RIMS 1999-2007. All Rights Reserved. No part of this manual is to be copied, modified or sold in any form without prior permission of RIMS EDUCATION for any further queries please visit our website at <http://www.rims-tech.co.uk>

WARRANTY

The media on which you receive RIMS Technologies software/hardware are warranted for defects in materials and workmanship, for a period of 90 days from date of shipment, as evidenced by receipts or other documentation. RIMS Technologies will, at its option, repair or replace software/hardware media that do not execute programming instructions if RIMS Technologies receives notice of such defects during the warranty period. RIMS Technologies does not warrant that the operation of the software/hardware shall be uninterrupted or error free.

A Return Material Authorization (RMA) number must be obtained from the factory and clearly marked on the outside of the package before any equipment will be accepted for warranty work. RIMS Technologies will pay the shipping costs of returning to the owner parts which are covered by warranty.

RIMS Technologies believes that the information in this document is accurate. The document has been carefully reviewed for technical accuracy. In the event that technical or typographical errors exist, RIMS Technologies reserves the right to make changes to subsequent editions of this document without prior notice to holders of this edition. The reader should consult RIMS Technologies if errors are suspected.

In no event shall RIMS Technologies be liable for any damages arising out of or related to this document or the information contained in it. EXCEPT AS SPECIFIED HEREIN, RIMS TECHNOLOGIES MAKES NO WARRANTIES, EXPRESS OR IMPLIED, AND SPECIFICALLY DISCLAIMS ANY WARRANTY OF MERCHANTABILITY OR FITNESS FOR A PARTICULAR PURPOSE. RIMS TECHNOLOGIES WILL NOT BE LIABLE FOR DAMAGES RESULTING FROM LOSS OF DATA, PROFITS, USE OF PRODUCTS, OR INCIDENTAL OR CONSEQUENTIAL DAMAGES, EVEN IF ADVISED OF THE POSSIBILITY THEREOF. This limitation of the liability of RIMS Technologies will apply regardless of the form of action, whether in contract or tort, including negligence. Any action against RIMS Technologies must be brought within one year after the cause of action accrues. RIMS Technologies shall not be liable for any delay in performance due to causes beyond its reasonable control. The warranty provided herein does not cover damages, defects, malfunctions, or service failures caused by owner's failure to follow the RIMS Technologies installation, operation, or maintenance instructions; owner's modification of the product; owner's abuse, misuse, or negligent acts; and power failure or surges, act of God, fire, flood, accident, actions of third parties, or other events outside reasonable control.

COPYRIGHT

Under the copyright laws, this publication may not be reproduced or transmitted in any form, electronic or mechanical, including photocopying, recording, storing in an information retrieval system, or translating, in whole or in part, without the prior written consent of RIMS Technologies.

TRADEMARKS

RIMS™, ThinPoint™, Power to Sense and Control™, INSPTEP™, LiveLabs™, RIMS Technologies™, BOX™, RIMS-Scope™, StateView™, rims-tech.co.uk™, RIMS-DAQ™, RIMS Students Zone™, and RIMS-Passport™ are trademarks of RIMS Technologies.

Product and company names mentioned herein are trademarks or trade names of rims technologies.

PATENTS

For patents covering RIMS Technologies products, refer to the RIMS Website www.rims-tech.co.uk.

WARNING REGARDING USE OF RIMS TECHNOLOGIES PRODUCTS

(1) RIMS Technologies products are not designed with components and testing for a level of reliability suitable for use in or in connection with surgical implants or as critical components in any life support systems whose failure to perform can reasonably be expected to cause significant injury to a human and also for industrial or specify critical application.

(2) In any application, including the above, reliability of operation of the software/hardware products can be impaired by adverse factors, including but not limited to fluctuations in electrical power supply, computer hardware malfunctions, computer operating system software/hardware fitness, fitness of compilers and development software/hardware used to develop an application, installation errors, software and hardware compatibility problems, malfunctions or failures of electronic monitoring or control devices, transient failures of electronic systems (hardware and/or software), unanticipated uses or misuses, or errors on the part of the user or applications designer (adverse factors such as these are hereafter collectively termed "system failures"). Any application where a system failure would create a risk of harm to property or persons (including the risk of bodily injury and death) should not be reliant solely upon one form of electronic system due to the risk of system failure. To avoid damage, injury, or death, the user or application designer must take reasonably prudent steps to protect against system failures, including but not limited to back-up or shut down mechanisms. Because each end-user system is customized and differs from rims technologies' testing platforms and because a user or application designer may use rims technologies products in combination with other products in a manner not evaluated or contemplated by rims technologies, the user or application designer is ultimately responsible for verifying and validating the suitability of rims technologies products whenever rims technologies products are incorporated in a system or application, including, without limitation, the appropriate design, process and safety level of such system or application.

(3) All efforts have been done to ensure the correctness of the information or media provided explicitly or implicitly for each training system. However RIMS technologies do not take any responsibility for the losses or otherwise any issues arising from the mistake in the media provided. RIMS would strive to ensure that the mistakes are corrected and communicated to all its customers.

General Information

- Understanding RIMS part numbers
- Signals Terminology

© RIMS 1999-2007. All Rights Reserved. No part of this manual is to be copied, modified or sold in any form without prior permission of RIMS EDUCATION
For any further queries please visit our website at
<http://www.rims-tech.co.uk>

1	UNDERSTANDING RIMS PART NUMBERS?
----------	---

Normally the trainer packaging contains the part numbers that you have ordered. You must understand the order number system for checking your packing note or even for later re-ordering of the equipment.

Trainer	-	Prefix	-	Sub-Category
DEV-2766	-	00	-	101

CODE	PF	SUB	Description
DEV-2765			Advanced D
DEV-2765	M	001	Trainer DEV
DEV-2765	00	101	Power Co
DEV-2765	00	331	Softw
DEV-2765	00	301	Use

Trainer name is the broad category e.g., 2766 is a Advanced Digital Trainer

The trainer has a prefix that represents the model Number of trainer e.g., 'M' or 'N'

Sub assembly is the hardware component that can be connected to the trainer some modules are compatible with other trainers as well but the part number would only be related to the trainer for which the have been designed

CODE	PF	SUB	Description
DEV-2765			Advanced D
DEV-2765	M	001	Trainer DEV
DEV-2765	00	101	Power Co
DEV-2765	00	331	Softw
DEV-2765	00	301	Use

Category is most important feature of this numbering. The under lying structure for category is same for all rims products, the category list is given here,

001-100	Hardware ID
101-200	Cables & Accessories
201-300	Special Attachments
301-400	Data Pack and Media
401-500	Services, Freight and Installations
501-600	Extended Warranties

Here are some common sub categories

101-110	Power Cord
111-120	Interconnecting aids & Data buses
121-130	Dust Covers

131-140	Bread boarding accessories
141-150	Specialized Power Cables
151-160	Extensions and boards
161-170	Cables Serial and Parallel
171-180	Specialized Cables
301-310	Operation Manuals and User Guide
321-330	Experiment Manuals
331-350	SOFTWARE
401-410	Services, Freight and Installations
501-510	Extended Warranties

CODE	P	SUB	Description
DEV-2765			Advanced U
DEV-2765	M	001	Trainer DEV
DEV-2765	00	101	Power Ca
DEV-2765	00	331	Softw
DEV-2765	00	301	Use

Please use the appropriate order code for either re-ordering components or the equipment from RIMS. The list is subject to further change without altering the existing structure. Please visit RIMS website for any further details about the updates on support pages.

2**SIGNALS TERMINOLOGY**

Following terms are used for various signals

Frequency

Number of cycles per second

Carrier Signal

Signal that is used as base for carrying signals over long distance usually high frequency signal

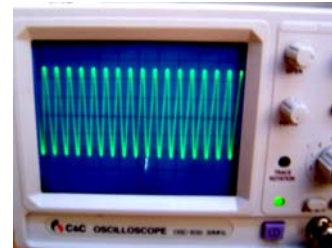

Carrier

Modulating Signal

Signal that is being modulated such as audio or low frequency signal relative to carrier

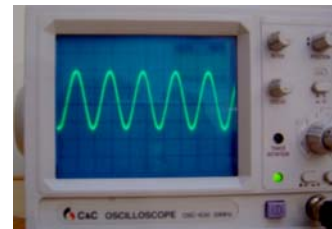

Modulating Signal/ Audio Signal

Modulated Signal

Signal after modulating on the carrier



Modulating Signal

Noise

Uncertainty or randomness in a signal that is represented by sufficient statistics such as mean, variance etc.

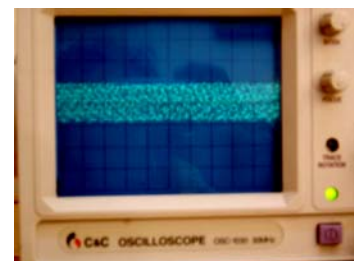

Noise

Clock

TTL or square wave for digital control

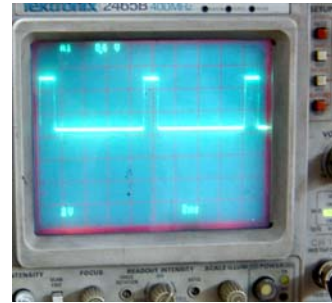

Clock/Pulse

Voltage

A certain level of signal fixed and not varying e.g., 2.3Volts

Drift

Slowly varying noise (undesired signal)

Offset/Bias

DC level in a signal



Offset/DC Level in AC Signal

Keying

Shifting frequencies within discrete levels

Audio Signal

Normally 300-3500Hz for communications application. Audible range is 20-20KHz, but the telephonic bandwidth is one given above. Above 10KHz and below 300Hz is considered as HI-FI (high fidelity)

Sampling Frequency

Rate at which a signal is digitized by a analog to digital converter

Power

Signal for driving the devices and running the system electronic, while other electronics signals are referred to as signal

Welcome to RIMS Advanced Electronics Trainer

List of experiments:

1. Two stage Amplifiers
2. Push-pull Amplifier
3. Wein Bridge Oscillator
4. Study of Schmitt Trigger
5. Hartley Oscillator
6. Phase Shift Oscillator
7. Study of A-stable Multi-vibrator
8. Differential Amplifier
9. Operational Amplifier
10. Precision Half Wave Rectifier
11. 555 Timer

Product Title: EXPERIMENTS

Document Code: DEV2766-00-321

Revision 2.0.0 dated February 2007

© RIMS 1999-2007. All Rights Reserved. No part of this manual is to be copied, modified or sold in any form without prior permission of RIMS EDUCATION for any further queries please visit our website at <http://www.rims-tech.co.uk>

STEP 1**TWO-STAGE AMPLIFIER TWO-STAGE
AMPLIFIER****ABSTRACT:**

This two-stage transistor amplifier illustrates the basic principles of operation of a common source FET stage and a common emitter BJT stage. The common source JFET stage, using self-bias, is used as the first stage to achieve a high input impedance for the amplifier. The second stage is a common emitter amplifier using voltage divider bias to provide additional voltage gain.

It is assumed that the student has had some background in basic transistor amplifier theory, including the use of AC equivalent circuits. After having done a complete prelab analysis, the student is expected to develop his or her own procedure for performing the lab experiment. The student should then analyze and thoughtfully summarize the results of the experiment in a written lab report. The use of Electronics Workbench as a computer simulation tool is also strongly recommended to enhance the learning process.

Objective:

The objective of the experiment is to investigate the operation of a two-stage FET and BJT transistor amplifier.

Theory:

The FET used here is an inexpensive small-signal n-channel JFET; a MPF102 or equivalent could be substituted, if desired.

For prelab, you can assume some typical values as follows: $\beta = 100$, $I_{DSS} = 10 \text{ ma}$, $V_{GS \text{ c/o}} = -4\text{V}$, $g_{mo} =$

4.8 mmhos (recall $g_{m0} = g_m$ at $V_{GS} = 0$), and $g_m = 3.3$ mmhos (mS) at the operating point IDQ.

You can effectively "measure" the input impedance of the amplifier Z_i by inserting a large test resistor in series with the input to the amplifier, and then measuring how much of the generator signal appears at the input of the amplifier; for example, if the input signal is reduced by one-half, then $Z_i =$ the test resistance.

You can determine the output impedance of the amplifier Z_o by temporarily placing a load resistor across the output of the amplifier, and determining how much the output signal drops as a result of this load (note: you will need to measure both the unloaded and loaded output voltages to determine Z_o). For example, if the output signal drops by one-half, then $Z_o =$ the load resistance.

ELECTRONICS WORKBENCH (EWB):

For a more accurate JFET simulation, you may need to change the ideal default n-channel JFET model in EWB to use the following JFET parameters (to more closely simulate the specified FET, with a typical I_{DSS} of 10 ma, and a $V_{GS\ c/o}$ of -4V): "VTO" (JFET "threshold" or cutoff voltage) = -4V, and "Beta" (JFET "transconductance coefficient") = $0.00063\ A/V^2$. (More information on these transistor parameters can be found in Electronics Workbench and Pspice reference books).

Procedure:

Build the circuit shown in following Figure. Before connecting up the ac input signal, verify that your measured DC voltages are reasonably close to the predicted values (if they are way off, you will need to troubleshoot the circuit before continuing). Then

connect a small ac sinewave input signal to the amplifier at a suitable frequency (a few kHz), and measure the voltage gain(s), and Z_i and Z_o . Record the waveforms seen on the oscilloscope (use DC coupling to see the composite signals) at various points in the circuit. Determine if your measured waveforms seem reasonable (close to the expected).

Hypothesize how could significantly increase the voltage gain of this circuit. Be sure to reduce V_i as needed to prevent overloading of the amplifier! Record your results, and compare them to the predicted values (include a table of % errors in your report).

Circuit Diagram:

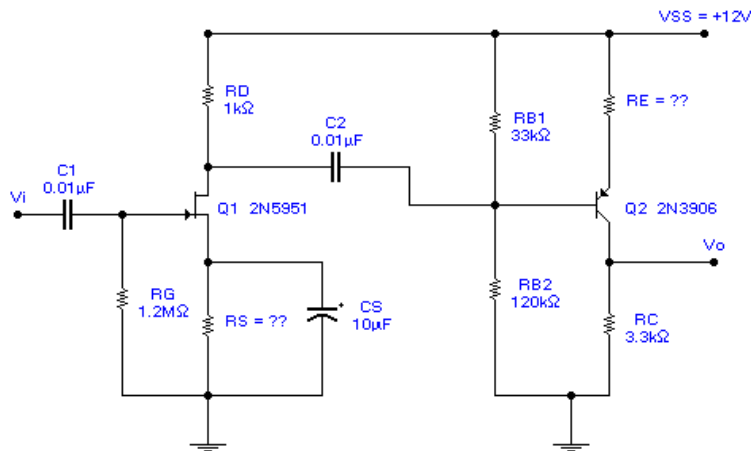

STEP 2**PUSH-PULL AMPLIFIER****Objective:**

How to build a "push-pull" class B amplifier using complementary bipolar transistors
 The effects of "crossover distortion" in a push-pull amplifier circuit
 Using negative feedback via an op-amp to correct circuit nonlinearities

Required Components and Equipments:

- Four 6 volt batteries
- Dual operational amplifier, model TL082 recommended
- One NPN power transistor in a TO-220 package
- One PNP power transistor in a TO-220 package
- One 1N914 switching diode
- One capacitor, 47 μF electrolytic, 35 WVDC
- Two capacitors, 0.22 μF , non-polarized
- One 10 k Ω potentiometer, linear taper

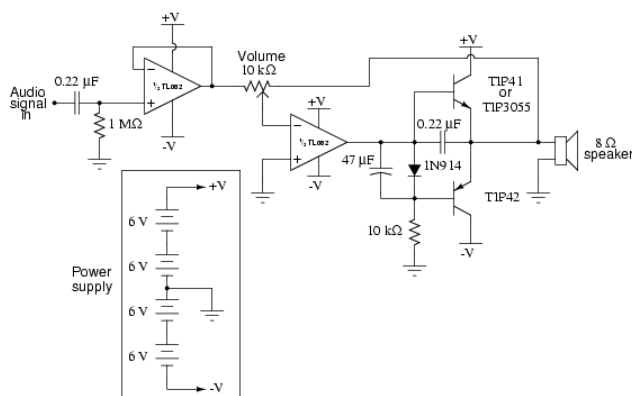
Circuit Diagram:

Procedure:

This experiment is for an audio amplifier suitable for amplifying the output signal from a small radio, tape player, CD player, or any other source of audio signals.

In this experiment, the transistors operate in pure class B mode. That is, they are never conducting at the same time. This saves energy and decreases heat dissipation, but lends itself to crossover distortion. The solution taken in this circuit is to use an op-amp with negative feedback to quickly drive the transistors through the "dead" zone producing crossover distortion and reduce the amount of "flattening" of the waveform during crossover.

The first (leftmost) op-amp shown in the schematic diagram is nothing more than a buffer. A buffer helps to reduce the loading of the input capacitor/resistor network, which has been placed in the circuit to filter out any DC bias voltage out of the input signal, preventing any DC voltage from becoming amplified by the circuit and sent to the speaker where it might cause damage. Without the buffer op-amp, the capacitor/resistor filtering circuit reduces the low-frequency ("bass") response of the amplifier, and accentuates the high-frequency ("treble").

The second op-amp functions as an inverting amplifier whose gain is controlled by the 10 k Ω potentiometer. This does nothing more than provides a volume control for the amplifier.

STEP 3	WEIN BRIDGE OSCILLATOR
---------------	-------------------------------

Objective:

Build basic Wein Bridge Oscillator to produce oscillation of different frequencies.

Theory:

Wien Bridge oscillator produces an approximately sinusoidal waveform. The circuit contains a positive feedback path into the RC network. The RC network signal attenuation is selective and has a maximum output at one frequency. The attenuation at this frequency is one third and when exactly matched by the gain of the Op-Amp oscillations are sustained.

Required Components and Equipments:

Quantity	Description
1	74LS85
1	5V power supply
1	Voltmeter
1	Oscilloscope with probe
8	2.5K resistor 1/4W
1	Signal generator
8	LED

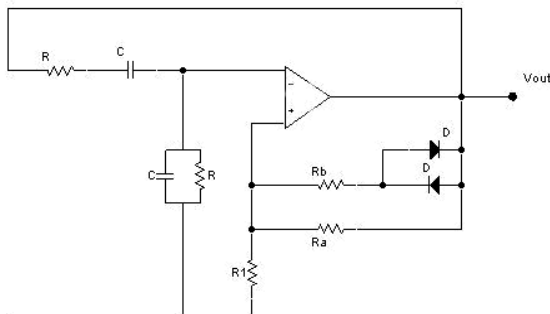
Circuit Diagram:

Procedure:

The frequency (in rads/sec) of oscillation is :

$$f = \frac{1}{RC}$$

Frequency (Hz)	Capacitance (μF)	Resistance (theoretical)	Resistance (standard)

The diodes are included to give amplitude control. At low amplitude levels they are high impedance and the gain of the amplifier is:

$$A_v \cong 1 + \frac{R_a}{R_1}$$

This is set to be just greater than 3. For the gain of value 10 the value of R_a will be _____ if the value of $R_1 = 10 \text{ K}\Omega$.

At high amplitude levels the diodes are low impedance and the gain is :

$$1 + \frac{R_a // R_b}{R_1}$$

This is set to be just less than 3. When the circuit is switched on this mechanism balances itself so that the gain is exactly equal to 3, thus giving stable signal amplitudes.

STEP 4	THE SCHMITT TRIGGER
---------------	----------------------------

Objective:

This experiment is just only to adjust the upper trip point, lower trip point, and hysteresis of a digital Schmitt trigger circuit. After finishing this experiment, You will learn the concept of how Schmitt trigger is working.

Theory

One of De Morgan's Laws is $(AB)' = \bar{A} + \bar{B}$. This means that the NAND gate function is equivalent to OR gate function with complemented inputs. From this experiment you can understand how to exchange gates for other gates.

Required Components and Equipments:

27K Ω resistor \times 1, 812K Ω resistor \times 1, 516K Ω resistor \times 3, 2.7K Ω resistor \times 1, 1K Ω resistor \times 3, 820K Ω resistor \times 1, 680K Ω resistor \times 1, 620 K Ω resistor \times 1, 560 K Ω resistor \times 1, 11 K Ω resistor \times 1.

Quantity	Description
1	7403
1	IN4149 diode
1	5V power supply
1	Voltmeter
1	Oscilloscope with probe
1	Signal generator
8	LED

Circuit Diagram:

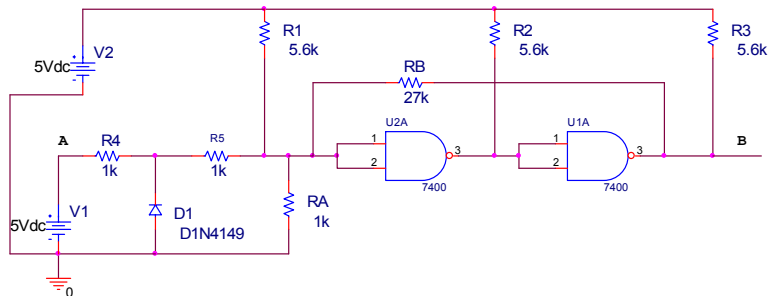

Procedure:

Step 1: Construct the circuit of above given Figure on the breadboard. Remember, IC7403's pin 14 connects to +5v, and its pin 7 connect to ground.

Step 2: First, RA has a value of 1 KΩ resistor, and RB to be fixed at 27 KΩ, connect output of point B to 12-Bit LED Display "0" position.

Step 3: Set DVM to +5v range, and connect it between point A and ground. Adjust the KΩ pot S0 the DVM reads 0V.

Step 4: Turn the KΩ pot carefully until the LED "0" light. Once the LED "0" is lighting, stop turning the 1KΩ pot. Record the readout value of DVM which has been connected between point A and ground into the UTP column of following table. That value is the upper trip point.

RA	UTP	LPT	Hysteresis
1KΩ			
820KΩ			
680KΩ			
620KΩ			
560KΩ			

Step 5: Adjust the $1\text{K}\Omega$ pot to increase the input voltage, to make sure the circuit is past the UPT and in the voltage region where the LED “0” will remain on.

Step 6: Next, slowly turn back the $1\text{K}\Omega$ pot until the LED “0” goes off. Record the value you observed on DVM into the LPT column of of the above given table. This value is the lower trip point.

Step 7: Exchange the different value of R_A listed in of the above given table, and repeat step 4 to step 6 for each value of R_A .

Step 8: As the LTP and LTP column completed, compute the hysteretic values by $\text{UPT}-\text{LTP}$. Record these values in the hysteretic column of the above given table.

Step 9: Exchange R_A to be fixed at $680\text{K}\Omega$ and R_B will be varied. The R_B will be $2.7\text{K}\Omega$, $812\text{K}\Omega$ and $27\text{K}\Omega$, then repeat the step 4 to step 6 and record the result. Observe the varying situation of UTP, LPT, and Hysteresis.

STEP 5**HARTLEY OSCILLATOR****Objective:**

To develop the understanding of Hartley Oscillator.

Theory:

The Hartley oscillator is an LC electronic oscillator that derives its feedback from a tapped coil in parallel with a capacitor (the tank circuit). A Hartley oscillator is therefore a type of inductively coupled variable frequency oscillator. It was invented by Ralph Hartley, who filed for a patent on June 1, 1915 and was awarded patent number 1,356,763 on October 26, 1920.

The HARTLEY OSCILLATOR is an improvement over the Armstrong oscillator. Although its frequency stability is not the best possible of all the oscillators, the Hartley oscillator can generate a wide range of frequencies and is very easy to tune. The Hartley will operate class C with self-bias for ordinary operation. It will operate class A when the output waveform must be of a constant voltage level or of a linear wave shape. The two versions of this oscillator are the series-fed and the shunt-fed. The main difference between the Armstrong and the Hartley oscillators lies in the design of the feedback (tickler) coil. A separate coil is not used. Instead, in the Hartley oscillator, the coil in the tank circuit is a split inductor. Current flow through one section induces a voltage in the other section to develop a feedback signal.

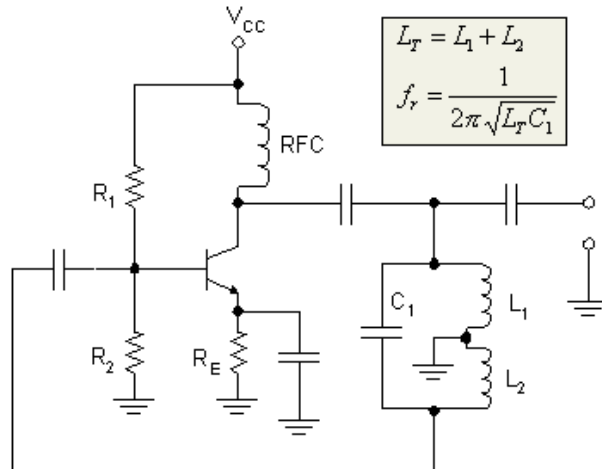
Circuit Diagram:**Procedure:**

Hartley oscillator is inductively coupled; variable frequency oscillators where the oscillator may be series or shunt fed. Hartley oscillators have the advantage of having one centre tapped inductor and one tuning capacitor. This arrangement simplifies the construction of a Hartley oscillator circuit.

For the circuit in Figure above, the output voltage is developed across L_1 and the feedback voltage is developed across L_2 . The attenuation caused by the feedback network (α_v) is found as:

$$\alpha_v = \frac{X_{L2}}{X_{L1}} = \frac{L_2}{L_1}$$

The tank circuit, just like in the Colpitts, determines the operating frequency of the Hartley oscillator. As the tapped inductors are in series, the sum of $(L_1 + L_2)$ must be used when calculating the value of f_r .

Fix L_1 and L_2 find the value of C for the given frequency. Verify the frequency produced by the oscillator on the oscilloscope.

STEP 6

PHASE SHIFT OSCILLATOR

Objective:

To develop the understanding of phase shift oscillator.

Theory:

The phase shift oscillator consists of an inverting amplifier stage coupled to a three stage RC filter network. The network contributes a total of 180 degrees phase shift. With the 180 degree shift due to the inverting amplifier, the signal returned to the amplifier input is shifted 360 degrees. The R and C values for the network must be chosen so that the gain of the amplifier and network stages is unity.

These are the necessary conditions for oscillation:

- 1) The phase shift through the amplifier and the network must be 360 degrees.
- 2) The magnitude of the gain of the amplifier and the feedback network must be one. (In practice try to make the gain slightly >1 .)

Together these two conditions are the Barkhausen Criterion or the necessary conditions for oscillation. Figure below shows the basic relationship.

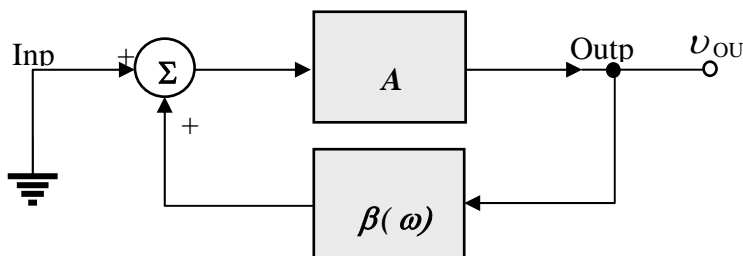

The block diagram of a phase shift oscillator

The amplifier stage is characterized by its DC gain value, A , and the transfer function (gain) of the feedback network is $\beta(\omega)$. Because the oscillator output is added to the input, the feedback is positive and the total phase shift is 360 degrees as required.

Procedure:

A practical implementation of this block diagram is shown in Figure below. In the typical design, $C_1 = C_2 = C_3$ and $R_1 = R_2 = R_3$ except for the addition of potentiometers for frequency and distortion adjustments. A simple zener diode circuit may be incorporated to insure output voltage stability, but the student need not consider stability in this exercise.

Circuit Diagram:

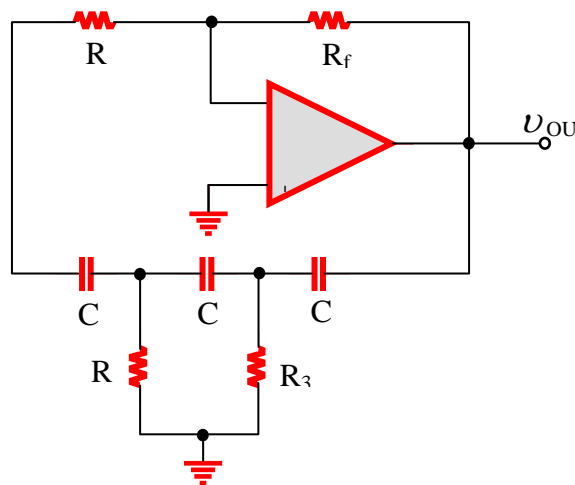

A practical phase shift oscillator without stabilizing circuitry and frequency adjustment

The phase shift oscillator is a simple device that illustrates the two general criteria. This circuit is shown below. The op-amp produces a negative gain, or phase shift of 180 degrees. The following RC combination produces an additional phase shift of exactly 180 deg at some frequency f_0 . Thus, a total phase shift of precisely 360 deg will be achieved at the frequency f_0 is.

$$\omega_0 = 2\pi f_0 = \frac{1}{RC\sqrt{6}} \quad ,$$

The amplifier gain, **A**, must be more than 29.
Choose R and C to generate a frequency in the range 100-1000 Hz. Choose R_f for an appropriate op-amp gain, and use a variable resistor for R_f .
Construct the phase-shift oscillator.

STEP 7

HALF AND FULL ADDER DESIGNING

Objective

1. To practice how to create square waveform by using CMOS inverters.
2. To study the method of finding the frequency of the oscillator.

Required Components and Equipments:

1. 74C04 × 1
2. 10KΩ resistor × 1, 10KΩ resistor × 1.
3. 100μF/ capacitor × 1.
4. RIMS Training System

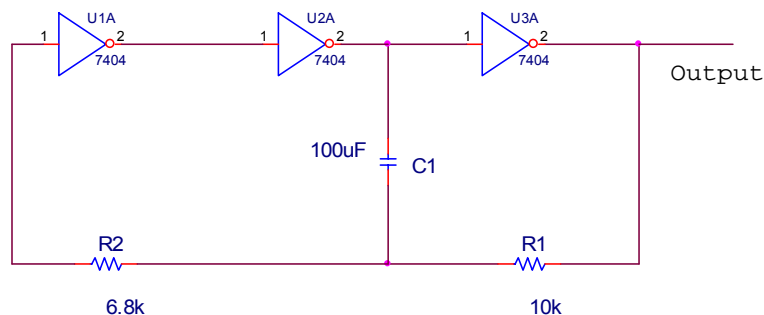
Circuit Diagram:**Procedure:**

Step 1: This oscillator is good low-frequency stability. The duty cycle approaches 50%. This configuration of circuit has vibrated frequency such as

$$f = \frac{1}{2C (0.405R_{eq} + 0.663 R_1)}$$

Where

$$R_{eq} = \frac{R_1 R_2}{R_1 + R_2}$$

Step 2: Install the circuit of the above Figure on the breadboard. Remember; connect 74C04's Pin 14 to +5v, and its pin 7 to ground. It's true that a 35v capacitor can withstand reverse polarities of less than 5v. Connect output point Y to 8 Bit LED Display "0".

Step 3: When the circuit is oscillating, this is one pulse when LED "0" light then darkens. Count the number of pulse, p that occur in 10 seconds and calculate the frequency

$$f = \frac{p}{10} Hz$$

Step 4: According to the formula of finding frequency, calculate the frequency and compare the result with that of step 3 above.

STEP 8**DIFFERENTIAL AMPLIFIER****Objectives:**

- Basic design of a differential amplifier circuit.
- Working definitions of *differential* and *common-mode* voltages

Required Components and Equipments:

- Two ± 5 or ± 6 volt supply
- Two NPN transistors -- models 2N2222 or 2N3403 recommended
- Two 10 k Ω potentiometers, single-turn, linear taper Two 22 k Ω resistors
- Two 10 k Ω resistors
- One 100 k Ω resistor
- One 1.5 k Ω resistor

Resistor values are not especially critical in this experiment, but have been chosen to provide high voltage gain for a "comparator-like" differential amplifier behavior.

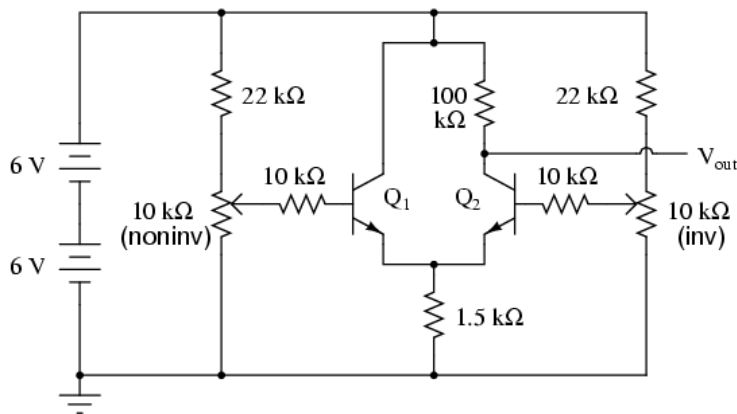
Circuit Diagram:

Procedure:

This circuit forms the heart of most operational amplifier circuits: the *differential pair*. In the form shown here, it is a rather crude differential amplifier, quite nonlinear and unsymmetrical with regard to output voltage versus input voltage(s). With a high voltage gain created by a large collector/emitter resistor ratio (100 k Ω /1.5 k Ω), though, it acts primarily as a comparator: the output voltage rapidly changing value as the two input voltage signals approach equality.

Measure the output voltage (voltage at the collector of Q₂ with respect to ground) as the input voltages are varied. Note how the two potentiometers have different effects on the output voltage: one input tends to drive the output voltage in the same direction (noninverting), while the other tends to drive the output voltage in the opposite direction (inverting). This is the essential nature of a *differential amplifier*: two complementary inputs, with contrary effects on the output signal. Ideally, the output voltage of such an amplifier is strictly a function of the *difference* between the two input signals. This circuit falls considerably short of the ideal, as even a cursory test will reveal.

An ideal differential amplifier ignores all *common-mode voltage*, which is whatever level of voltage common to both inputs. For example, if the inverting input is at 3 volts and the noninverting input at 2.5 volts, the differential voltage will be 0.5 volts (3 - 2.5) but the common-mode voltage will be 2.5 volts, since that is the lowest input signal level. Ideally, this condition should produce the same output signal voltage as if the inputs were set at 3.5 and 3 volts, respectively (0.5 volts differential, with a 3 volt common-mode voltage). However, this circuit does

not give the same result for the two different input signal scenarios. In other words, its output voltage depends on both the differential voltage *and* the common-mode voltage.

As imperfect as this differential amplifier is, its behavior could be worse. Note how the input signal potentiometers have been limited by 22 k Ω resistors to an adjustable range of approximately 0 to 4 volts, given a power supply voltage of 12 volts. If you'd like to see how this circuit behaves without any input signal limiting, just bypass the 22 k Ω resistors with jumper wires, allowing full 0 to 12 volt adjustment range from each potentiometer.

Do not worry about building up excessive heat while adjusting potentiometers in this circuit! Unlike the current mirror circuit, this circuit is protected from thermal runaway by the emitter resistor (1.5 k Ω), which doesn't allow enough transistor current to cause any problem.

STEP 9

OPERATIONAL AMPLIFIER

Objective:

- Design of a differential amplifier circuit using current mirrors.
- Effects of negative feedback on a high-gain differential amplifier.
- Understand the basic operation of an Op-amp.
-

Required Components and Equipments:

- Two 6-volt batteries
- Four NPN transistors -- models 2N2222 or 2N3403 recommended
- Two PNP transistors -- models 2N2907 or 2N3906 recommended
- Two 10 k Ω potentiometers, single-turn.
- One 270 k Ω resistor
- Three 100 k Ω resistors
- One 10 k Ω resistor "

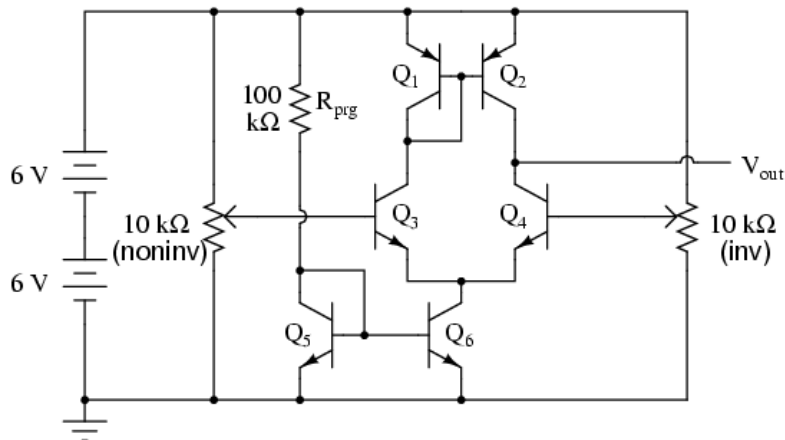
Circuit Diagram:

Procedure:

This circuit design improves on the differential amplifier shown previously. Rather than use resistors to drop voltage in the differential pair circuit, a set of current mirrors is used instead, the result being higher voltage gain and more predictable performance. With a higher voltage gain, this circuit is able to function as a working operational amplifier, or *op-amp*. Op-amps form the basis of a great many modern analog semiconductor circuits, so understanding the internal workings of an operational amplifier is important.

PNP transistors Q_1 and Q_2 form a current mirror which tries to keep current split equally through the two differential pair transistors Q_3 and Q_4 . NPN transistors Q_5 and Q_6 form another current mirror, setting the *total* differential pair current at a level predetermined by resistor R_{prg} .

Measure the output voltage (voltage at the collector of Q_4 with respect to ground) as the input voltages are varied. Note how the two potentiometers have different effects on the output voltage: one input tends to drive the output voltage in the same direction (noninverting), while the other tends to drive the output voltage in the opposite direction (inverting). You will notice that the output voltage is most responsive to changes in the input when the two input signals are nearly equal to each other.

Once the circuit's differential response has been proven (the output voltage sharply transitioning from one extreme level to another when one input is adjusted above and below the other input's voltage level), you are ready to use this circuit as a real op-amp. A simple op-amp circuit called a *voltage*

follower is a good configuration to try first. To make a voltage follower circuit, directly connect the output of the amplifier to its inverting input. This means connecting the collector and base terminals of Q_4 together, and discarding the "inverting" potentiometer:

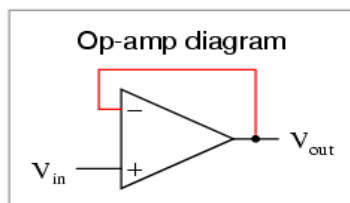
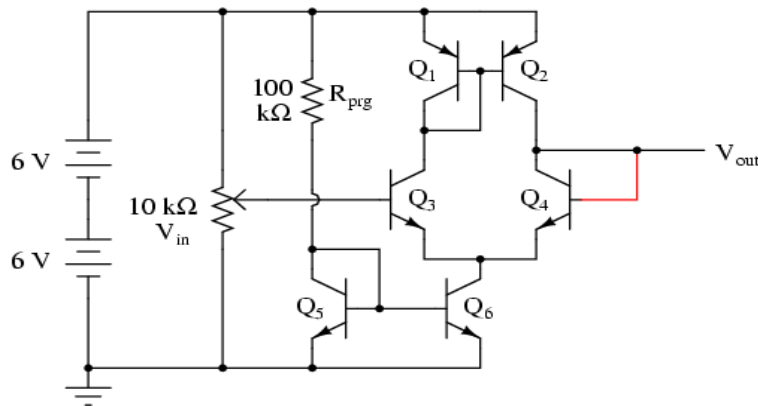

Note the triangular symbol of the op-amp shown in the lower schematic diagram. The inverting and non-inverting inputs are designated with (-) and (+) symbols, respectively, with the output terminal at the right apex. The feedback wire connecting output to inverting input is shown in red in the above diagrams.

As a voltage follower, the output voltage should "follow" the input voltage very closely, deviating no more than a few hundredths of a volt. This is a much more precise follower circuit than that of a single common-collector transistor, described in an earlier experiment!

A more complex op-amp circuit is called the *noninverting amplifier*, and it uses a pair of resistors in the feedback loop to "feed back" a fraction of the output voltage to the inverting input, causing the amplifier to output a voltage equal to some multiple of the voltage at the noninverting input. If we use two equal-value resistors, the feedback voltage will be 1/2 the output voltage, causing the output voltage to become twice the voltage impressed at the noninverting input. Thus, we have a voltage amplifier with a precise gain of 2:

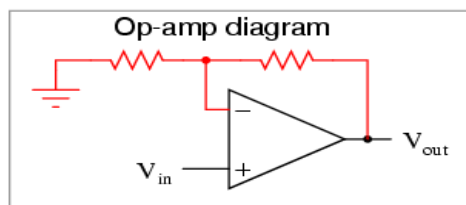
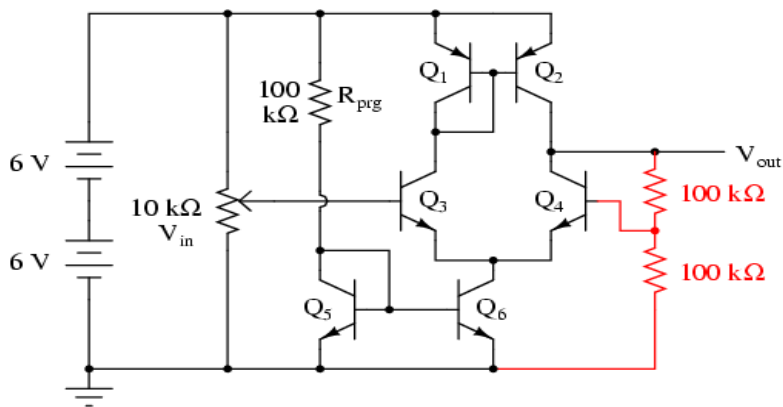

As you test this non inverting amplifier circuit, you may notice slight discrepancies between the output and input voltages. According to the feedback resistor values, the voltage gain should be exactly 2. However, you may notice deviations in the order of several hundredths of a volt between what the output voltage is and what it should be. These deviations are due to imperfections of the differential amplifier circuit, and may be greatly diminished if we add more amplification stages to

increase the differential voltage gain. However, one way we can maximize the precision of the existing circuit is to change the resistance of R_{prg} . This resistor sets the lower current mirror's control point, and in so doing influences many performance parameters of the op-amp. Try substituting difference resistance values, ranging from 10 k Ω to 1 M Ω . Do not use a resistance less than 10 k Ω , or else the current mirror transistors may begin to overheat and thermally "run away."

Some operational amplifiers available in prepackaged units provide a way for the user to similarly "program" the differential pair's current mirror, and are called *programmable* op-amps. Most op-amps are not programmable, and have their internal current mirror control points fixed by an internal resistance, trimmed to precise value at the factory.

STEP 10**PRECISION HALF AND FULL WAVE RECTIFIER****Objective:**

To understand the functionality of precision half and full wave rectifiers.

Circuit Diagram:

Fig 1; Precision Half-wave Rectifier

Theory:

Precision rectifiers have a linear forward characteristic without knee voltage, U_s . This is the reason for their application in measurement technology. A simple half-wave rectifier can be realised with an operational amplifier and two diodes used in a non-linear feedback (see Fig.1). The forward characteristic is described by

$$U_2 = -\frac{R_2}{R_1} U_1 \quad \text{for } U_1 < 0 ,$$

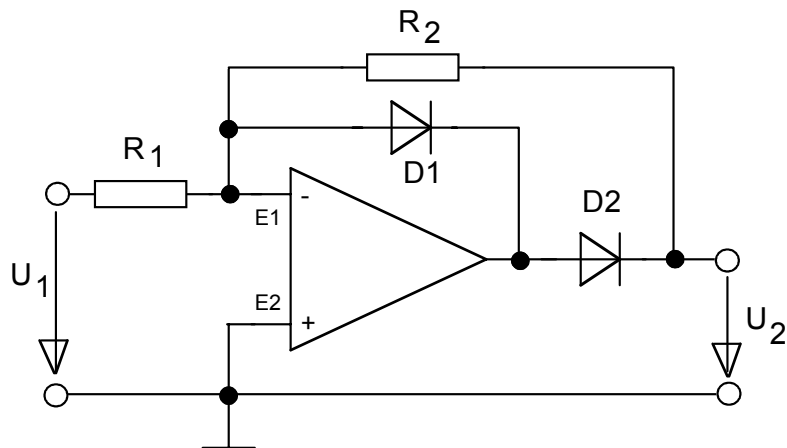
$$U_2 = 0 \quad \text{for } U_1 > 0 .$$

The reason for this special behaviour is, that for an

input voltage $-U_s < U_1 < +U_s$ the OPamp works without feedback with the open-loop gain. Using this principle also a full-wave rectifier can be developed (see Fig.3).

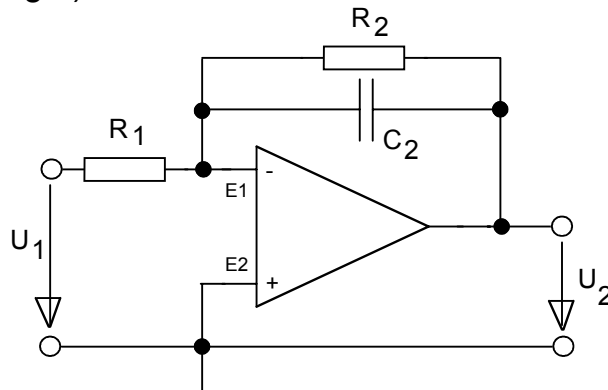

Fig.2: Low Pass Filter

A low pass filter is characterised by the cut-off frequency, ω_c : only signals with a lower frequency are transmitted. Using a periodic signal with a period

$$T \ll \tau = 1/\omega_c$$

(τ time constant), the output voltage is proportional to the mean value. Fig.3

shows a simple circuit of a so-called active low pass (first order filter) using an operational amplifier. The transfer function of this circuit is given by

$$\bar{U}_2 = -\frac{R_2}{R_1} \cdot \frac{1}{T} \int_0^T U_1 dt .$$

Procedure:

Caution: All circuits should be constructed using the RIMS trainer. Check conscientiously the circuit you build and determine its correct function by measurement and comparison of the signals at different circuit points using oscilloscope. Before applying power to the circuit, please, ask the teacher to check the circuit for you.

Use the full-wave rectifier circuit shown in Fig.3 completed with a low pass shown in Fig.2 (use $R_1 = R_2 = 10k\Omega$, $C = 1\mu F$, OPamp 5). Use the following input signals generated with the function generator Agilent 33120A:

1. Harmonic AC voltage ($f \approx 250\text{Hz}$).
2. Harmonic AC voltage with offset ($U_{\text{off}} = \pm 0.5\hat{U}$ and $\pm\hat{U}$).
3. AC voltages with different other slopes.

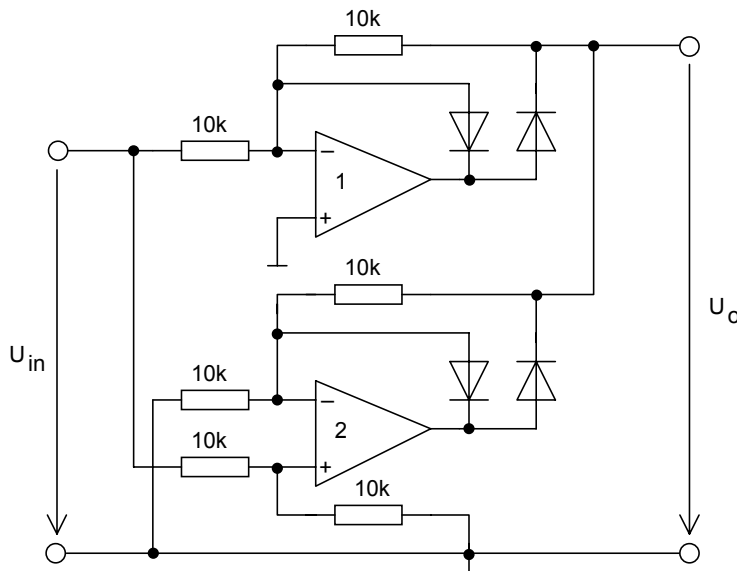

Fig.3: Full-wave Rectifier

Measure all input signals using the oscilloscope and calculate the mean value from their analytic formula.

Measure the output voltage using the multimeter and compare the calculated and measured results.

STEP 11	THE ASTABLE MULTIVIBRATOR-555
----------------	--------------------------------------

Objective:

To study the operation of a 555 timer and understand the principle of an astable multivibrator.

Required Components and Equipments:

Oscilloscope
 2.2KΩ resistor × 1, 47KΩ resistor × 1
 0.01μF ceramic-disk capacitor ×1, 100μF/35V electrolytic capacitor × 1
 555 timer 1C × 1
 RIMS Trainer DEV-2766

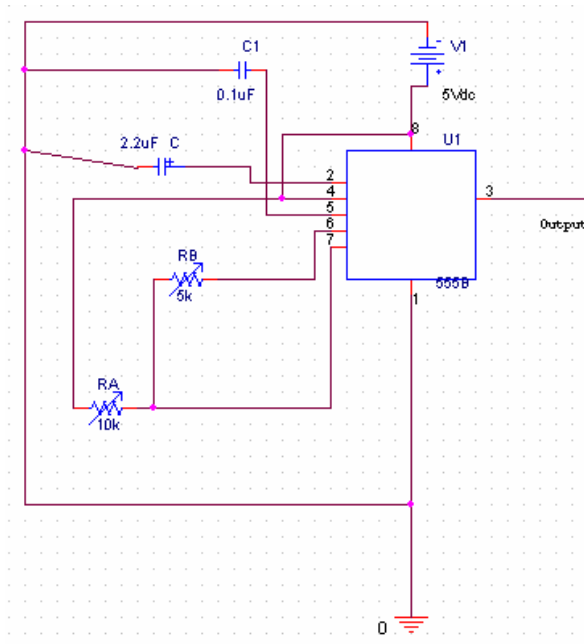
Circuit Diagram:**Theory:**

The frequency of a 555 timer based Astable Multivibrator is determined by two time periods. The

first time period t_1 is the ON time and is equal to $0.663 (R_A + R_B) C_1$. The second time period t_2 is the OFF time and equals $0.663 R_B C_1$. The period of the output waveform is the sum of the two time delays, that is

$$T = t_1 + t_2 = 0.663 (R_A + 2R_B) C_1$$

The frequency is the reciprocal of the period T:

$$f = 1/T = \frac{1.44}{(R_A + 2R_B) C_1}$$

The duty cycle, D is t_1 divided by the period of the waveform (T), that is

$$D = \frac{t_1}{T} = \frac{0.663 (R_A + R_B) C_1}{0.663 (R_A + 2R_B) C_1} \times 100\% = \frac{R_A + R_B}{R_A + 2R_B} \times 100\%$$

Procedure:

Step 1: Construct the Multivibrator of Fig. above on the breadboard. Adjust the **Variable Reference** DC power supply of your DEV-2761 to 9V and connect it to $+V_{CC}$ of Fig. 13-1. Connect the output of Fig.13-1 at point Y to an 8 Bit LED.

Step 2: The LED should flash at a rate of about once every 7 sec. Set DVM to 20V range and connect it across C_1 . Watch the DVM's display; note that it changes between $1/3 V_{CC}$ (3V) and $2/3 V_{CC}$ (6V). C_1 is charging when the display is rising and discharging when the display is falling. The LED is on when C_1 is charging, and off when C_1 is discharging.

Step 5: Calculate the duty cycle of the vibrator by using the formula of duty cycle given above. The

result will be

$$D = \frac{R_A + R_B}{R_A + 2R_B} = \frac{2.2 + 4n}{2.2 + 2(4n)} = 51.14\%$$

Step 4: Select R_A , R_B , and C_1 so that the output frequency can be measured by the oscilloscope. Connect Oscilloscope between point Y and ground, and observe the output waveform. Calculate the duty cycle from the waveform observed, and compare it with the result you acquired from the formula for duty cycle.

**RIMS****EDUCATION****EU, USA and Canada**

Weston Villa, 37 Wolsey Road, Esher, Surrey
United Kingdom KT10 8NT

www.rims-tech.co.uk

Middle East & Asia Pacific

632-B Chakala Scheme-III Rawalpindi
Pakistan 46000

www.rimsedu.com



Product Title: RIMS Advanced Digital Trainer

Document Code: DEV2766-00-321

Revision 2.0.1 dated February 2007

© RIMS 1999-2007. All Rights Reserved. No part of this manual is to be copied, modified or sold in any form without prior permission of RIMS EDUCATION

For any further queries please visit our website at

<http://www.rims-tech.co.uk>