

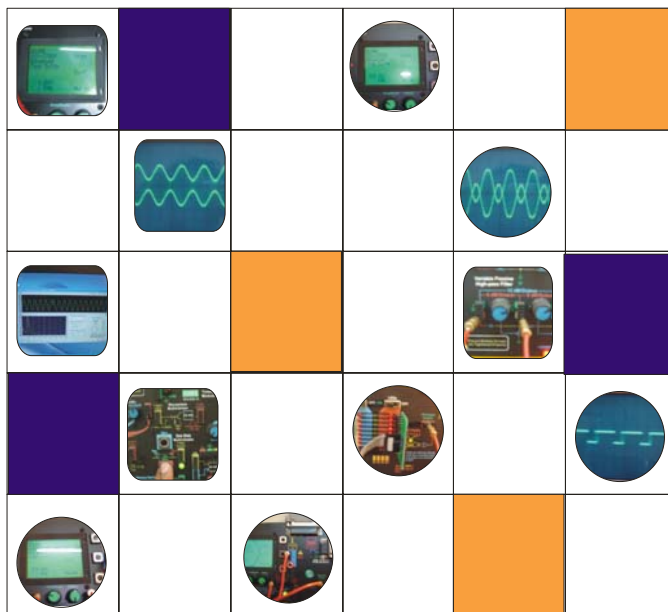
RIMSResearch Instrumentation
& Measurement Systems**DEV-2766**

Advanced Digital Trainer

EXPERIMENTS

Volume 6

PART NO. 2766-00-321



**COMPREHENSIVE AND ILLUSTRATED
EASY EXPERIMENTS STARTUP
LAB MANUAL**

THANK YOU FOR CHOOSING RIMS EDUCATION PRODUCTS AND SERVICES

Once you have made it through this guide, you will have a firm grip on your lab experiments and operations of the RIMS product you are using. How to get your training equipment operational, basic maintenance and setting up desired experiments will just be a breeze. Everything you need for a quick and easy start is presented here—useful hints and tips makes it simple to conduct your lab and hands-on training sessions. We are happy that you have joined our vast community of over 30 thousand valued users, which grow as we bring you the latest technology at most competitive prices. We value your business and hope that you will enjoy being an important member of the RIMS Education Community.

Customer Support Team



EU, USA and Canada

Weston Villa, 37 Wolsey Road, Esher, Surrey
United Kingdom KT10 8NT
www.rims-tech.co.uk

Middle East & Asia Pacific

632-B Chakala Scheme-III Rawalpindi
Pakistan 46000
www.rimsedu.com

© RIMS 1999-2007. All Rights Reserved. No part of this manual is to be copied, modified or sold in any form without prior permission of RIMS EDUCATION for any further queries please visit our website at <http://www.rims-tech.co.uk>

WARRANTY

The media on which you receive RIMS Technologies software/hardware are warranted for defects in materials and workmanship, for a period of 90 days from date of shipment, as evidenced by receipts or other documentation. RIMS Technologies will, at its option, repair or replace software/hardware media that do not execute programming instructions if RIMS Technologies receives notice of such defects during the warranty period. RIMS Technologies does not warrant that the operation of the software/hardware shall be uninterrupted or error free.

A Return Material Authorization (RMA) number must be obtained from the factory and clearly marked on the outside of the package before any equipment will be accepted for warranty work. RIMS Technologies will pay the shipping costs of returning to the owner parts which are covered by warranty.

RIMS Technologies believes that the information in this document is accurate. The document has been carefully reviewed for technical accuracy. In the event that technical or typographical errors exist, RIMS Technologies reserves the right to make changes to subsequent editions of this document without prior notice to holders of this edition. The reader should consult RIMS Technologies if errors are suspected.

In no event shall RIMS Technologies be liable for any damages arising out of or related to this document or the information contained in it. EXCEPT AS SPECIFIED HEREIN, RIMS TECHNOLOGIES MAKES NO WARRANTIES, EXPRESS OR IMPLIED, AND SPECIFICALLY DISCLAIMS ANY WARRANTY OF MERCHANTABILITY OR FITNESS FOR A PARTICULAR PURPOSE. RIMS TECHNOLOGIES WILL NOT BE LIABLE FOR DAMAGES RESULTING FROM LOSS OF DATA, PROFITS, USE OF PRODUCTS, OR INCIDENTAL OR CONSEQUENTIAL DAMAGES, EVEN IF ADVISED OF THE POSSIBILITY THEREOF. This limitation of the liability of RIMS Technologies will apply regardless of the form of action, whether in contract or tort, including negligence. Any action against RIMS Technologies must be brought within one year after the cause of action accrues. RIMS Technologies shall not be liable for any delay in performance due to causes beyond its reasonable control. The warranty provided herein does not cover damages, defects, malfunctions, or service failures caused by owner's failure to follow the RIMS Technologies installation, operation, or maintenance instructions; owner's modification of the product; owner's abuse, misuse, or negligent acts; and power failure or surges, act of God, fire, flood, accident, actions of third parties, or other events outside reasonable control.

COPYRIGHT

Under the copyright laws, this publication may not be reproduced or transmitted in any form, electronic or mechanical, including photocopying, recording, storing in an information retrieval system, or translating, in whole or in part, without the prior written consent of RIMS Technologies.

TRADEMARKS

RIMS™, ThinPoint™, Power to Sense and Control™, INSPTEP™, LiveLabs™, RIMS Technologies™, BOX™, RIMS-Scope™, StateView™, rims-tech.co.uk™, RIMS-DAQ™, RIMS Students Zone™, and RIMS-Passport™ are trademarks of RIMS Technologies.

Product and company names mentioned herein are trademarks or trade names of rims technologies.

PATENTS

For patents covering RIMS Technologies products, refer to the RIMS Website www.rims-tech.co.uk.

WARNING REGARDING USE OF RIMS TECHNOLOGIES PRODUCTS

(1) RIMS Technologies products are not designed with components and testing for a level of reliability suitable for use in or in connection with surgical implants or as critical components in any life support systems whose failure to perform can reasonably be expected to cause significant injury to a human and also for industrial or specify critical application.

(2) In any application, including the above, reliability of operation of the software/hardware products can be impaired by adverse factors, including but not limited to fluctuations in electrical power supply, computer hardware malfunctions, computer operating system software/hardware fitness, fitness of compilers and development software/hardware used to develop an application, installation errors, software and hardware compatibility problems, malfunctions or failures of electronic monitoring or control devices, transient failures of electronic systems (hardware and/or software), unanticipated uses or misuses, or errors on the part of the user or applications designer (adverse factors such as these are hereafter collectively termed "system failures"). Any application where a system failure would create a risk of harm to property or persons (including the risk of bodily injury and death) should not be reliant solely upon one form of electronic system due to the risk of system failure. To avoid damage, injury, or death, the user or application designer must take reasonably prudent steps to protect against system failures, including but not limited to back-up or shut down mechanisms. Because each end-user system is customized and differs from rims technologies' testing platforms and because a user or application designer may use rims technologies products in combination with other products in a manner not evaluated or contemplated by rims technologies, the user or application designer is ultimately responsible for verifying and validating the suitability of rims technologies products whenever rims technologies products are incorporated in a system or application, including, without limitation, the appropriate design, process and safety level of such system or application.

(3) All efforts have been done to ensure the correctness of the information or media provided explicitly or implicitly for each training system. However RIMS technologies do not take any responsibility for the losses or otherwise any issues arising from the mistake in the media provided. RIMS would strive to ensure that the mistakes are corrected and communicated to all its customers.

General Information

- Understanding RIMS part numbers
- Signals Terminology

© RIMS 1999-2007. All Rights Reserved. No part of this manual is to be copied, modified or sold in any form without prior permission of RIMS EDUCATION
For any further queries please visit our website at
<http://www.rims-tech.co.uk>

1

UNDERSTANDING RIMS
PART NUMBERS?

Normally the trainer packaging contains the part numbers that you have ordered. You must understand the order number system for checking your packing note or even for later re-ordering of the equipment.

Trainer	-	Prefix	-	Sub-Category
DEV-2766	-	00	-	101

CODE	PF	SUB	Description
DEV-2765			Advanced D
DEV-2765	M	001	Trainer DEV
DEV-2765	00	101	Power Co
DEV-2765	00	331	Softw
DEV-2765	00	301	Use

Trainer name is the broad category e.g., 2766 is a Advanced Digital Trainer

The trainer has a prefix that represents the model Number of trainer e.g., 'M' or 'N'

Sub assembly is the hardware component that can be connected to the trainer some modules are compatible with other trainers as well but the part number would only be related to the trainer for which the have been designed

CODE	PF	SUB	Description
DEV-2765			Advanced D
DEV-2765	M	001	Trainer DEV
DEV-2765	00	101	Power Co
DEV-2765	00	331	Softw
DEV-2765	00	301	Use

Category is most important feature of this numbering. The under lying structure for category is same for all rims products, the category list is given here,

001-100	Hardware ID
101-200	Cables & Accessories
201-300	Special Attachments
301-400	Data Pack and Media
401-500	Services, Freight and Installations
501-600	Extended Warranties

Here are some common sub categories

101-110	Power Cord
111-120	Interconnecting aids & Data buses
121-130	Dust Covers

131-140	Bread boarding accessories
141-150	Specialized Power Cables
151-160	Extensions and boards
161-170	Cables Serial and Parallel
171-180	Specialized Cables
301-310	Operation Manuals and User Guide
321-330	Experiment Manuals
331-350	SOFTWARE
401-410	Services, Freight and Installations
501-510	Extended Warranties

CODE	P	SUB	Description
DEV-2785			Advanced U
DEV-2785	M	001	Trainer DEV
DEV-2785	00	101	Power Ca
DEV-2785	00	331	Softw
DEV-2785	00	301	Use

Please use the appropriate order code for either re-ordering components or the equipment from RIMS. The list is subject to further change without altering the existing structure. Please visit RIMS website for any further details about the updates on support pages.

2**SIGNALS TERMINOLOGY**

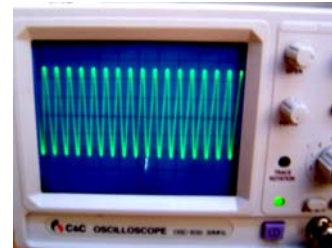
Following terms are used for various signals

Frequency

Number of cycles per second

Carrier Signal

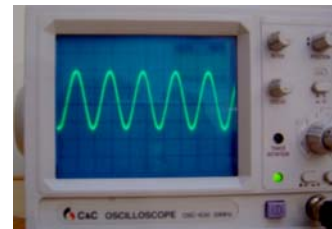
Signal that is used as base for carrying signals over long distance usually high frequency signal



Carrier

Modulating Signal

Signal that is being modulated such as audio or low frequency signal relative to carrier



Modulating Signal/ Audio Signal

Modulated Signal

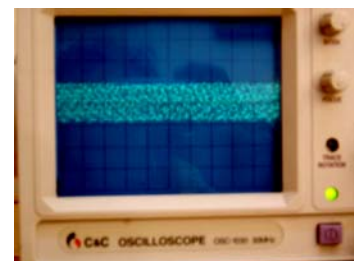
Signal after modulating on the carrier



Modulating Signal

Noise

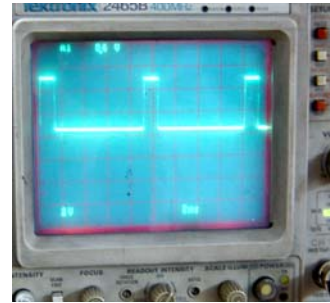
Uncertainty or randomness in a signal that is represented by sufficient statistics such as mean, variance etc.



Noise

Clock

TTL or square wave for digital control



Clock/Pulse

Voltage

A certain level of signal fixed and not varying e.g., 2.3Volts

Drift

Slowly varying noise (undesired signal)

Offset/Bias

DC level in a signal



Offset/DC Level in AC Signal

Keying

Shifting frequencies within discrete levels

Audio Signal

Normally 300-3500Hz for communications application. Audible range is 20-20KHz, but the telephonic bandwidth is one given above. Above 10KHz and below 300Hz is considered as HI-FI (high fidelity)

Sampling Frequency

Rate at which a signal is digitized by a analog to digital converter

Power

Signal for driving the devices and running the system electronic, while other electronics signals are referred to as signal

Welcome to RIMS Advanced Digital Trainer

List of experiments:

1. Verify Ohms law keeping
 - Voltage constant
 - Resistance constant
2. Demonstrate the properties of series and parallel circuits
3. To prove that the algebraic sum of incoming and outgoing currents is zero (KVL, KCL)
4. To prove the Kirchoff's law by using
 - Loop method
 - Node method
5. Verify Norton Theorem
6. Thevenin's Theorem
7. Maximum power transfer Theorem
8. Superposition Theorem
9. DC/AC behavior of Capacitor (charging and discharging)
10. Demonstrate the production of magnetic field around the inductor
11. demonstrate the mutual inductance using the simple transformer
12. study the sine wave of Oscilloscope
13. Energy transfer principle using transformer.

Product Title: EXPERIMENTS

Document Code: DEV2766-00-321

Revision 2.0.0 dated October 2007

© RIMS 1999-2007. All Rights Reserved. No part of this manual is to be copied, modified or sold in any form without prior permission of RIMS EDUCATION for any further queries please visit our website at <http://www.rims-tech.co.uk>

STEP 1

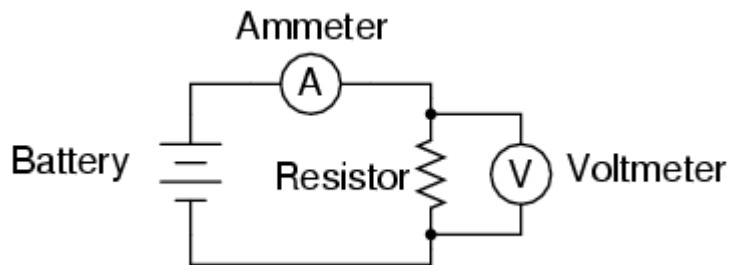
OHM'S LAW

Objective:

- Voltmeter use
- Ammeter use
- Ohmmeter use
- Use of Ohm's Law

Required Components and Equipments:

- Calculator (or pencil and paper for doing arithmetic)
- 0-12 volt variable battery
- Variable resistance 100 k Ω in value
- Multi-meter
-

Diagram of Circuit:**Voltage constant:****Procedure:**

- 1) Using your multi-meter adjust the variable battery to 6 volts.
- 2) Using your multi-meter set the resistance to 10 K Ω .

- 3) Construct the circuit as shown in the figure above on your trainer breadboard.
- 4) Measure the current value and note down in the table given below.
- 5) Do not change the voltage value, but change the resistor value to a value given in the table below, measure the current again.
- 6) Keep changing the resistance and complete the table.
- 7) Draw the graph between the current and resistor values in the table, resistor values on x-axis.

Resistance (K Ω)	Current (mA)	Voltage (V)
10		Fixed to 6 Volts
25		
46		
78		
93		

Resistance constant:

Procedure:

- 1) Using your multi-meter adjust the variable battery to 1 volt.
- 2) Using your multi-meter set the resistance to 10 K Ω .

- 3) Construct the circuit as shown in the figure above on your trainer breadboard.
- 4) Measure the current value and note down in the table given below.
- 5) Do not change the resistance value, but change the voltage value to a value given in the table below, measure the current again.
- 6) Keep changing the voltage and complete the table.
- 7) Draw the graph between the current and voltage values in the table, voltage values on x-axis.

Voltage (V)	Current (mA)	Resistance (K Ω)
1		Fixed to 10 K Ω
3		
5		
7		
9		

STEP 2

SERIES AND PARALLEL CIRCUITS

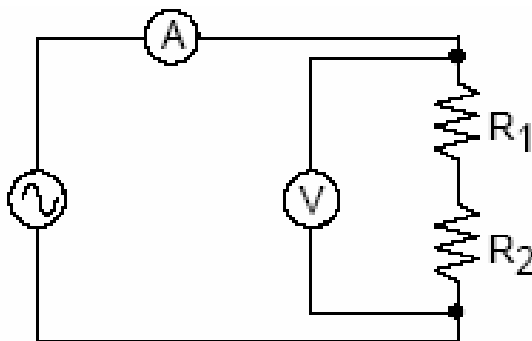
Objective:

The purpose of this experiment is to observe the behavior of current & voltage for two resistors connected in series and in parallel, and measure the equivalent resistance of these pairings. Also, you will observe the results of a short circuit and an open circuit.

Be sure to connect the voltmeters and ammeters *after* the circuit has been assembled. This will ensure that the circuit is connected properly for your measurements.

Required Components and Equipments:

- 12 volt battery
- Any two resistors
- Multi-meter

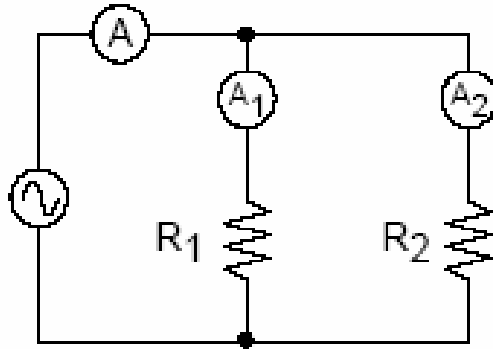
Series Circuits**Diagram of Circuit:**

Procedure:

- 1) Set the multi-meter so that it can measure resistance directly. Measure the resistance of each resistor *without* connecting them to a circuit.
- 2) Connect the two resistors together in *series* (don't connect the resistors to any voltage source or other meters at this time). Use the multi-meter to measure the *equivalent resistance* for the pair of resistors, and compare this reading to the sum of the measured resistances from the previous step.
- 3) Now connect the two resistors and an ammeter in series to the voltage source of 12 volts as shown at right. Measure the *voltage* in these three locations:
 - i. Across the *pair* of resistors (as shown in above figure).
 - ii. Across *each* resistor.
 - iii. Across the battery.
- 4) *Be sure to draw a circuit diagram for each position of the voltmeter! Check that $V = V_1 + V_2$.*
- 5) Remove the voltmeter from the circuit. Check that the current is set to 0.5 A. Turn off the supply by pressing the power button, and move the ammeter *between* the two resistors. Turn on the supply, and record the current. Repeat once again, this time moving the ammeter to the *other* side of the pair of resistors. What do you notice

Parallel Circuits

Diagram of Circuit:



Procedure:

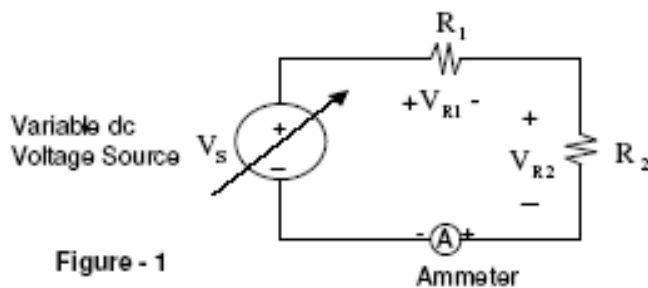
- 1) Turn the knob on the supply down to zero, and turn it off. Connect the two resistors in parallel, including two ammeters in the circuit, as shown in the figure above. Turn on the supply, and adjust the knob to 12 volts. Record the current that passes through each resistor. Without changing the supply setting, measure the voltage across each resistor.
- 2) If you were to place a *third* ammeter in the circuit to measure the current drawn from the supply, what do you think it will read? Connect a third meter, and check your prediction.
- 3) Disconnect the two resistors from the rest of the circuit, but leave the pair connected to each other. Measure the equivalent resistance for the pair of resistors as before, and compare your reading to the expected value.

STEP 3**KIRCHOFF'S VOLTAGE & CURRENT LAW****Objective:**

This experiment is designed to help you verify Kirchhoff's current and voltage laws using simple dc circuits.

Required Components and Equipments:

Quantity	Description
1	74LS85
1	Variable power supply
1	Multi-meter
1	220 Ω
1	330 Ω
1	680 Ω

KIRCHOFF'S VOLTAGE LAW**Diagram of Circuit:**

Procedure:

For the circuit given in Figure-1, select $R_1 = 220 \Omega$ and $R_2 = 680 \Omega$. Compute the voltage drop across each resistor when the current in the circuit is 15 mA.

Voltage drop across R_1 (V_{R1}) =

Voltage drop across R_2 (V_{R2}) =

Determine the applied voltage V_S . $V_S =$

Compute the power dissipated by each resistor.

$P_{R1} =$ $P_{R2} =$

Power rating must always be checked prior to activating the circuit.

Now build the circuit. Adjust the variable dc voltage source to a value equal to V_S as computed above.

Is the current in the circuit 15 mA? If not, explain why not?

Adjust the voltage source, if needed, to obtain a current of 15 mA.

Measure the voltage drop across each resistor and compare it with its computed value.

To verify Kirchhoff's voltage law, show that $V_{R1} + V_{R2} = V_S$

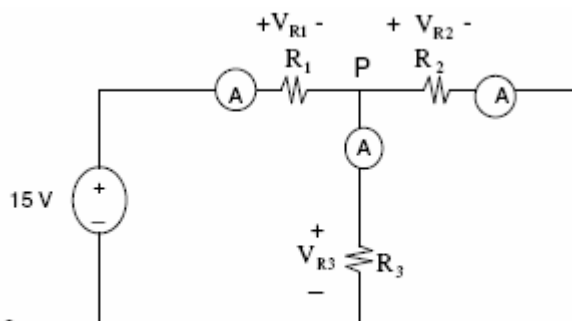
KIRCHOFF'S CURRENT LAW**Diagram of Circuit:**

Figure - 2

Procedure:

For the circuit given in **Figure-2**, select $R_1 = 680 \Omega$, $R_2 = 330 \Omega$ and $R_3 = 220 \Omega$. Theoretically determine the current in each resistor. Mark the polarity on each ammeter so that it shows a positive reading.

Current through $R_1 =$

Current through $R_2 =$

Current through $R_3 =$

Now build the circuit. Measure each current and compare it with its computed value.

Measured current through $R_1 =$

Percent error =

Measured current through $R_2 =$

Percent error =

Measured current through $R_3 =$

Percent error =

Verify Kirchhoff's current law at node P.

Is $V_{R2} = V_{R3}$? Explain

Is $V_{R1} + V_{R2} = 15 \text{ V}$? Explain.

Is $V_{R1} + V_{R3} = 15 \text{ V}$? Explain

STEP 4**KIRCHOFF'S LAW (LOOP & NODE METHOD)****Objective:**

- 1) To construct a planar circuit having two voltage sources and five resistors.
- 2) To study node voltages and mesh currents.
- 3) To compare calculated and measured results using both nodal and mesh analysis.

Theory**SUMMARY OF NODE VOLTAGE (N-V) METHOD**

1. Number of equations needed is one less than the number of essential nodes, except as noted in item 7 below.
2. Select one of the essential nodes as a reference node (the node with the most branches usually is a good choice).
3. Then assign node voltages at the other essential nodes. By definition, node voltages are a "rise" above ref. node.
4. Next, generate N-V equations by summing currents at each non-reference node (using KCL). Currents are to be considered leaving the node, unless a current source exists in the branch (then you use the direction of the arrow for determining the sign).
5. If a voltage source exists in the branch, subtract or add its voltage (depending on polarity) to the node voltage before dividing by the resistance in the branch.
6. When a dependent source exists, you must express the controlling voltage or current in terms of the assigned node voltages.
7. If a voltage source is connected directly between an essential node and the ref. node, that reduces

the number of equations needed.

8. If a voltage source (independent or dependent) exists between two non-reference nodes, then you can use the super node concept, and proceed as in above to write the equations.

Note that the voltage existing in the super node must be expressed as a function of the node voltages to obtain one equation.

SUMMARY OF MESH CURRENT (M-C) METHOD

1. Number of equations needed is equal to the number of meshes (windows) in the network, except as noted in 7. below.

2. The M-C method is used for planar networks only, where the network is drawn with no crossing branches.

3. Assign clockwise mesh current in each mesh. A mesh current exists only in the perimeter of a mesh. In some parts of the mesh, the mesh current may be the same as the branch current.

4. Next, generate M-C equations by summing voltages around each mesh (using KVL). Voltages are to be considered positive unless a voltage source exists in the mesh (then you use the polarity of the voltage to determine the sign). Where two meshes have a common branch, a net current (one mesh current minus the other) must be used to express voltage in that branch.

5. When a dependent source exists, you must express the controlling voltage or current in terms of the assigned mesh currents.

6. If a current source (independent or dependent) is common to two meshes, then you can use the super mesh concept, and proceed as in 4. Above to write the equations.

Note that the "common" current source must be expressed as a function of the mesh currents to obtain one equation.

7. If a current source exists in the outer perimeter of the circuit, KVL need not be applied to that mesh (because that mesh current has to be equal to the current in that source).

NOTE: The primary advantage of both the N-V and M-C methods is that you can analyze a circuit (which has many unknowns) with a fewer number of simultaneous equations.

However - WHEN IS N-V METHOD USED INSTEAD OF M-C METHOD? - AND VICE VERSA

1. One approach: Use the one which requires the fewest number of simultaneous equations.
2. Look at location of v-sources and i-sources. The analysis may be simplified if v-sources exist between essential nodes and reference you might select, or if an i-sources exist in the outer perimeter of meshes.
3. If a certain voltage is of primary interest, then the N-V method will probably be the best, or if your primary interest in a certain current, then the M-C method will probably be the best choice.
4. The N-V method can be applied to any circuit, whereas the M-C method requires that the circuit have a planar network.
5. When you have more v-sources than i-sources, the best selection will probably be the N-V method.
6. When you have more i-sources, the best selection will probably be the M-C method.
7. The mesh method is probably used more than it should be.
8. Other than the above, experience and intuition will probably cause the best selection.

Required Components and Equipments:

DC Power Supply.
Digital Multimeter (DMM)

Resistors one each: 1.5 k Ω , 2.2 k Ω , 4.7 k Ω , 5.6 k Ω , and 6.8 k Ω .

Diagram of Circuit:

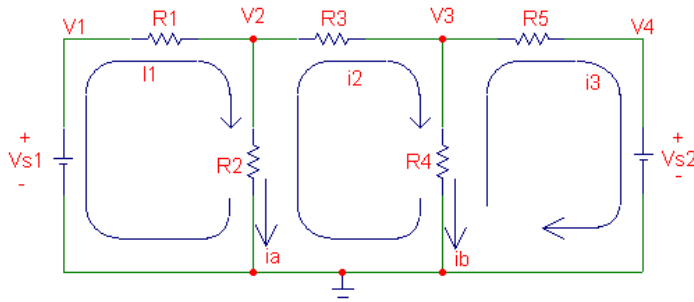


Figure 1

Procedure:

1. Construct the circuit shown in Figure 1 using available power supply, resistors, breadboard, and connecting wires provided. $R_1 = 2.2 \text{ k}\Omega$, $R_2 = 4.7 \text{ k}\Omega$, $R_3 = 6.8 \text{ k}\Omega$, $R_4 = 5.6 \text{ k}\Omega$, $R_5 = 1.5 \text{ k}\Omega$.
2. Set $V_{s1} = 18 \text{ V}$ and $V_{s2} = -18 \text{ V}$. Note that while V_{s1} and V_{s2} have the same magnitude, V_{s1} is positive and is connected to Node 1 and V_{s2} is negative and connected to Node 4.
3. Note that the reference node, nodal voltages (V_1 , V_2 , V_3 , & V_4) and mesh currents (I_1 , i_2 , & i_3) have already been designated.
4. Measure all nodal voltages (not Branch voltages) and the mesh currents (not Branch currents i_a , & i_b).
5. Don't forget to measure all the resistor Values.

COMPARISONS AND QUESTIONS:

1. From your measured mesh currents, calculate the value of the branch currents i_a and i_b shown in Figure 1.
2. By observation, what are the values of V_1 and V_4 ? With the given values of V_{s1} and V_{s2} .
3. Node Equations:
 - a. Set up the nodal equations for the circuit, and solve for V_2 and V_3 , using **nominal** values of resistances and **nominal** voltage sources. **Show all your calculations in your laboratory notebook.**
 - b. Compare all measured node voltages with the calculated values.
 - c. Repeat a & b using the measured values of resistances and measured values of the source voltages. You may use a computer or calculator to solve the equations.
4. Mesh Equations:
 - a. Set up the mesh equations for the circuit, and solve for the three mesh currents, using **nominal** values of resistances and the **nominal** voltage sources. **Show your calculations in your laboratory notebook.**
 - b. Compare all **measured** mesh currents with the **calculated** values.
 - c. Repeat a & b using the **measured** values of resistance and **measured** values of the source voltages. You may use a computer or calculator to solve the equations.

5. Calculate the power absorbed by resistors R2 and R4. For each resistor calculate power by using three different methods: $P=VI$, $P=I^2R$, $P=V^2/R$. Use measured resistances, measured node voltages, and the branch currents calculated from the measured mesh currents. Explain any differences in the power obtained by the three methods. Are the differences small enough to be explained by the specified meter errors? Justify your answers.

STEP 5	NORTON THEROM
---------------	---------------

Objective:

The objective of this experiment is to study Norton's theorem and its application in circuit analysis.

Theory:

In this experiment we will study the theorem which greatly simplifies analysis of many linear circuits. Norton may be considered as a corollary to the Thevenin's theorem. Equivalent circuit obtained using Norton's theorem consists of an independent current source in parallel with a resistor.

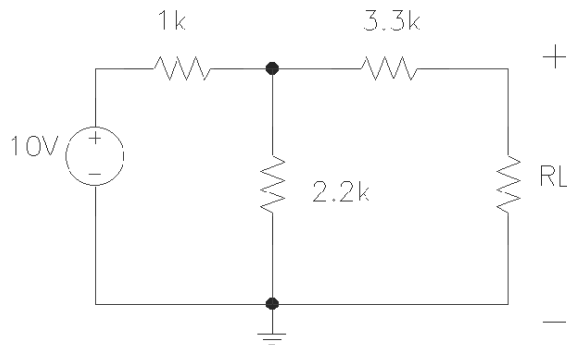
Norton's Model:

The following outlines the steps needed for evaluating I_N and R_N in the laboratory:

1. Measure current flowing between short circuited terminals of network. This is I_{SC} or I_N .
2. Using a multimeter measure equivalent resistance between terminals of network, after all the independent current and voltage sources have been replaced with open-circuits and short-circuits, respectively.

Required Components and Equipments:

- 1k Resistors (x3)
- Resistor series
 - 1.2k Ω (x1)
 - 2.2k Ω (x1)
 - 3.3k Ω (x1)

Diagram of Circuit:**Procedure:**

Construct above given figure. Measure I_N and R_N for your circuit using the steps outlined before in the Norton Model.

Use $R_L = 1.2\text{ K}\Omega$ as the load for above given figure. Measure I_L and V_L .

Replace everything in network of above given figure, except R_L , with its Norton equivalent and measure I_L and V_L .

STEP 6

THEVENIN'S THEOREM

Objective:

The objective of this experiment is to study Thevenin's theorem and its application in circuit analysis.

Theory:

In this experiment we will study the theorem which greatly simplifies analysis of many linear circuits. It is named after a French engineer working in telegraphy, M. L. Thevenin. He first published a statement of his theorem in 1883. Using Thevenin's theorem it is possible to obtain an equivalent circuit of any linear circuit composed of an independent voltage source in series with a resistor.

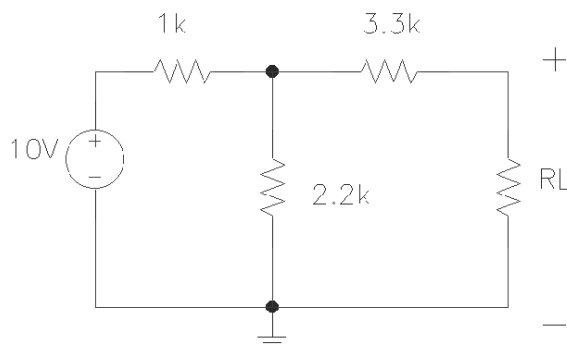
Thevenin's Model:

In the laboratory the Thevenin's model (V_{TH} and R_{TH}) may be obtained by the following steps:

1. Measure voltage at the open circuited terminals of the network. This voltage is V_{OC} or V_{TH} .
2. Using a multimeter measure the resistance between terminals of network, after all independent voltage and current sources have been replaced with short-circuits and open-circuits, respectively.

Required Components and Equipments:

- 1k Resistors (x3)
- Resistor series
 - 1.2k Ω (x1)
 - 2.2k Ω (x1)
 - 3.3k Ω (x1)

Diagram of Circuit:**Procedure:**

Construct above given figure. Measure V_{TH} and R_{TH} for your circuit using the steps outlined before in the Thevenin Model.

Use $R_L = 1.2\text{ K}\Omega$ as the load for above given figure. Measure I_L and V_L .

Replace everything in network of above given figure, except R_L , with its Thevenin equivalent and measure I_L and V_L

STEP 7**MAXIMUM POWER TRANSFER THEOREM****Objective**

Verify the Maximum Power Transfer Theorem.

Required Components and Equipments:

560 Ω x 2, 820 Ω x 1.

One variable resistor from 0 to 10 K Ω .

One DMM.

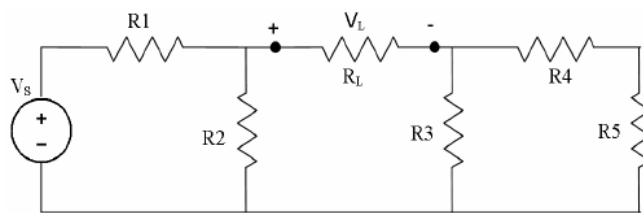
Diagram of Circuit:

Figure 1.

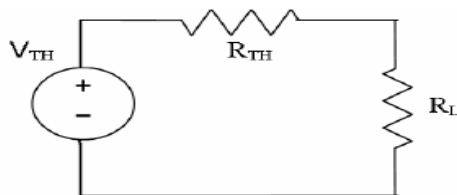


Figure 2: Thévenin Equivalent Circuit of Figure 1

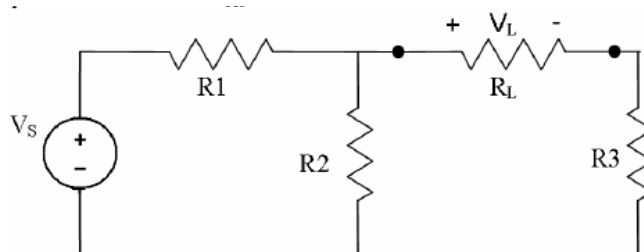


Figure 3: Maximum Power Transfer

Procedure:

1. Construct the circuit as in Figure 3 using the following values:
 - $V_S = 10\text{ V}$
 - $R_1 = R_2 = 560\ \Omega$
 - $R_3 = 820\ \Omega$
 - $R_L = \text{Variable resistor}$
2. Connect the DMM across R_L for measuring the load voltage.
3. To find the value of R_L for which maximum power is transferred, vary the resistances between $600\ \Omega$ to $1200\ \Omega$ and note down V_L for each case.
4. The value of R_L at which V_L is maximum, gives the load resistance for maximum power transfer.

STEP 8

SUPERPOSITION THEOREM

Objectives:

Verification of Superposition Theorem

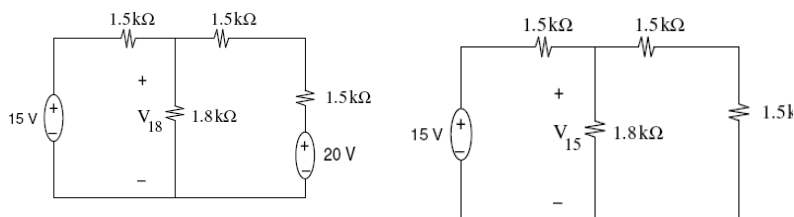
Suggested equipment list:

Multimeters x 2

Resistors	How many
1 k Ω	1
1.5 k Ω	3
1.8 k Ω	1

Theory:

The superposition theorem is based upon the linearity theorem. It is applied to a circuit containing two or more independent sources. According to this theorem, the total response of a circuit is the algebraic sum of all individual responses obtained by considering one independent source at a time. The response can either be a voltage drop across or current through a circuit element.

Diagram of Circuit:

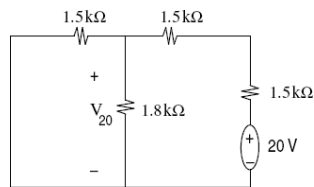


Figure-3

Procedure:

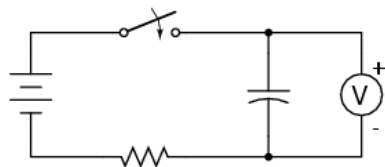
1. For the circuit given in **Figure-1**, theoretically determine the total voltage drop V_{18} across the $1.8\text{ k}\Omega$ resistor by using any method (the node-voltage, the mesh-current, or the source transformation). This is the expected voltage drop across the $1.8\text{ k}\Omega$ resistor.
2. Now set up the circuit in **Figure-1** and measure the voltage drop across the $1.8\text{ k}\Omega$ resistor. Compute the percent error between the computed and measured values.
3. In order to apply superposition theorem, let us first set the 20-V source to zero and leave
4. 15-V source in the circuit as shown in **Figure-2**.
5. First theoretically determine V_{15} .
6. Set up the circuit and measure V_{15} . Find the percent error between the measured and the computed values of V_{15} .
7. Now set the 15-V source to zero and apply the 20-V source.
8. Theoretically determine V_{20} as indicated in **Figure-3**.
9. Set up this circuit and measure V_{20} . Find the percent error between the computed and measured values of V_{20} .
10. Now verify the superposition theorem by showing that $V_{18} = V_{15} + V_{20}$

STEP 9**CAPACITOR (CHARGING AND DISCHARGING)****Objective:**

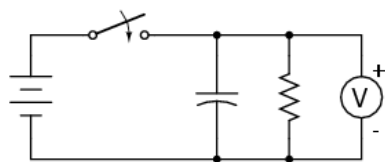
- Capacitor charging action
- Capacitor discharging action

Required Components and Equipments

- 6 volt battery
- Two large electrolytic capacitors, 1000 μF
- Two 1 k Ω resistors
- One toggle switch, SPST ("Single-Pole, Single-Throw")

Diagram of Circuit:

Charging circuit



Discharging circuit

Procedure:

1. Build the "charging" circuit and measure voltage across the capacitor when the switch is closed. Notice how it increases slowly over time, rather than suddenly as would be the case with a resistor. You can "reset" the capacitor back to a voltage of zero by shorting across its terminals with a piece of wire.
2. The "time constant" (τ) of a resistor capacitor circuit is

calculated by taking the circuit resistance and multiplying it by the circuit capacitance. For a 1 k Ω resistor and a 1000 μ F capacitor, the time constant should be 1 second. This is the amount of time it takes for the capacitor voltage to increase approximately 63.2% from its present value to its final value: the voltage of the battery.

3. It is educational to plot the voltage of a charging capacitor over time on a sheet of graph paper, to see how the inverse exponential curve develops. In order to plot the action of this circuit, though, we must find a way of slowing it down. A one-second time constant doesn't provide much time to take voltmeter readings!
4. We can increase this circuit's time constant two different ways: changing the total circuit resistance, and/or changing the total circuit capacitance. Given a pair of identical resistors and a pair of identical capacitors, experiment with various series and parallel combinations to obtain the slowest charging action. You should already know by now how multiple resistors need to be connected to form a greater total resistance, but what about capacitors? This circuit will demonstrate to you how capacitance changes with series and parallel capacitor connections. Just be sure that you insert the capacitor(s) in the proper direction: with the ends labeled negative (-) electrically "closest" to the battery's negative terminal!
5. The discharging circuit provides the same kind of changing capacitor voltage, except this time the voltage jumps to full battery voltage when the switch closes and slowly falls when the switch is opened. Experiment once again with different combinations of resistors and capacitors, making sure as always that the capacitor's polarity is correct

STEP 10MAGNETIC FIELD AROUND THE
INDUCTOR**Objective:**

- Application of the left-hand rule
- Electromagnet construction
-

Required Components and Equipments:

- 6-volt battery
- Magnetic compass
- Small permanent magnet
- Spool of 28-gauge magnet wire
- Large bolt, nail, or steel rod
- Electrical tape

Magnet wire is a term for thin-gauge copper wire with enamel insulation instead of rubber or plastic insulation. Its small size and very thin insulation allow for many "turns" to be wound in a compact coil. You will need enough magnet wire to wrap hundreds of turns around the bolt, nail, or other rod-shaped steel form.

Be sure to select a bolt, nail, or rod that is magnetic. Stainless steel, for example, is non-magnetic and will not function for the purpose of an electromagnet coil! The ideal material for this experiment is soft iron, but any commonly available steel will suffice.

Diagram of Circuit:**Procedure:**

Wrap a single layer of electrical tape around the steel bar (or bolt, or nail) to protect the wire from abrasion. Proceed to wrap several hundred turns of wire around the steel bar, making the coil as even as possible. It is okay to overlap wire, and it is okay to wrap in the same style that a fishing reel wraps line around the spool. The only rule you must follow is that all turns must be wrapped around the bar in the same direction (no reversing from clockwise to counter-clockwise!). I find that a drill press works as a great tool for coil winding: clamp the rod in the drill's chuck as if it were a drill bit, then turn the drill motor on at a slow speed and let it do the wrapping! This allows you to feed wire onto the rod in a very steady, even manner.

After you've wrapped several hundred turns of wire around the rod, wrap a layer or two of electrical tape over the wire coil to secure the wire in place.

Scrape the enamel insulation off the ends of the coil

wires for connection to jumper leads, then connect the coil to a battery.

When electric current goes through the coil, it will produce a strong magnetic field: one "pole" at each end of the rod. This phenomenon is known as electromagnetism. The magnetic compass is used to identify the "North" and "South" poles of the electromagnet.

With the electromagnet energized (connected to the battery), place a permanent magnet near one pole and note whether there is an attractive or repulsive force. Reverse the orientation of the permanent magnet and note the difference in force.

Electromagnetism has many applications, including relays, electric motors, solenoids, doorbells, buzzers, computer printer mechanisms, and magnetic media "write" heads (tape recorders, disk drives).

You might notice a significant spark whenever the battery is disconnected from the electromagnet coil: much greater than the spark produced if the battery is simply short-circuited. This spark is the result of a high-voltage surge created whenever current is suddenly interrupted through the coil. The effect is known as inductive "kickback" and is capable of delivering a small but harmless electric shock! To avoid receiving this shock, do not place your body across the break in the circuit when de-energizing! Use one hand at a time when un-powering the coil and you'll be perfectly safe.

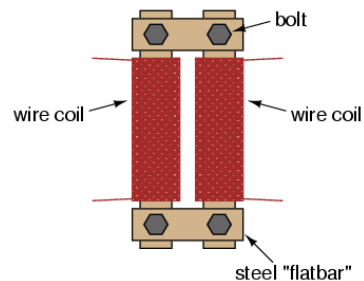
STEP 11	MUTUAL INDUCTANCE USING SIMPLE TRANSFORMER	
----------------	--	--

Objective:

To understand the Mutual Inductance Using Simple Transformer.

Required Components and Equipments:

- Steel flatbar, 4 pieces
- Miscellaneous bolts, nuts, washers
- 28 gauge "magnet" wire
- Low-voltage AC power supply

Diagram of Circuit:**Theory:**

When an AC voltage is applied to the primary coil, it creates a magnetic flux in the core, which induces AC voltage in the secondary coil in-phase with the source voltage. This effect is called mutual inductance: the induction of a voltage in one coil in response to a change in current in the other coil. Like normal (self-) inductance, it is measured in the unit of Henrys, but unlike normal inductance it is symbolized by the capital letter "M" rather than the letter "L":

Inductance

$$e = L \frac{di}{dt}$$

Mutual inductance

$$e_2 = M \frac{di_1}{dt}$$

Where,

e_2 = voltage induced in secondary coil

i_1 = current in primary coil

Procedure:

Wrap two, equal-length bars of steel with a thin layer of electrically-insulating tape. Wrap several hundred turns of magnet wire around these two bars. You may make these windings with an equal or unequal number of turns, depending on whether or not you want the transformer to be able to "step" voltage up or down. I recommend equal turns to begin with, and then experiment later with coils of unequal turn count.

Join those bars together in a rectangle with two other, shorter, bars of steel. Use bolts to secure the bars together (it is recommended that you drill bolt holes through the bars before you wrap wire around them).

Check for shorted windings (ohmmeter reading between wire ends and steel bar) after you're finished wrapping the windings. There should be no continuity (infinite resistance) between the winding and the steel bar. Check for continuity between winding ends to ensure that the wire isn't broken open somewhere within the coil. If either resistance measurements indicate a problem, the winding must be re-made.

Power your transformer with the low-voltage output of the "power supply" described at the beginning of this chapter. Do not power your transformer directly from wall-socket voltage (220 volts), as your home-made windings really aren't rated for any significant voltage!

STEP 12 SINE WAVE OF OSCILLOSCOPE**Objective:**

- Use the function generator to generate a waveform with a specified voltage at a specified frequency.
- Use the DMM to measure AC voltage and current.
- Use the oscilloscope to measure direct current (DC) and AC voltages.
- Use the oscilloscope to measure amplitude and frequency of periodic AC signals.

Required Components and Equipments:

- Function Generator
- Oscilloscope
- DMM

Theory:

When measuring AC values with the meter, the meter does not measure the peak value of the waveform; rather it measures the root mean square (RMS) value. The peak value can be obtained from the RMS value using the following simple relationships:

For a sine wave: $V_p = \sqrt{2} * V_{rms}$

For a triangle wave: $V_p = \sqrt{3} * V_{rms}$

For a square wave: $V_p = V_{rms}$

where

V_{rms} = RMS voltage value

V_p = peak voltage value

These conversion factors will be needed in the lab. Note that most multimeters, including the ones we have in the lab, do not actually measure true RMS but measure a pseudo-RMS which is calibrated to be equal to the true RMS for a sine wave. For other waveforms the meter reading may be off by a constant factor, depending on the particular waveform, from the true RMS value. A meter which accurately measures RMS for any waveform is called a “true RMS” meter.

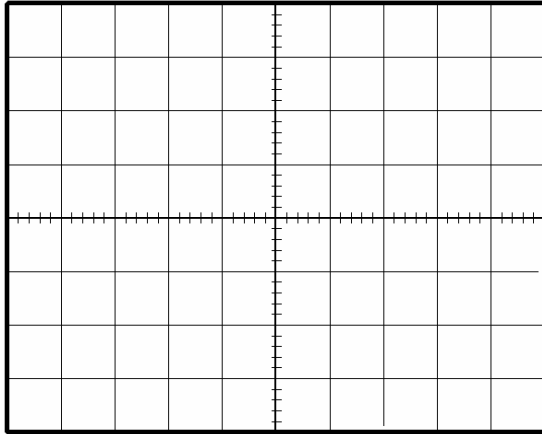
The oscilloscope is extremely useful in viewing a periodic voltage signal. The shape of the waveform can be observed and both voltage and frequency of a periodic signal can be measured using the oscilloscope

Procedure:

Turn on the oscilloscope and wait a few seconds for it to warm up. When it is ready, the beam will appear on the reticle. If needed, adjust the size and sharpness of the beam using the INTENSITY and FOCUS knobs. Make sure that the inner concentric knobs in the Volts/Div and Sec/Div are set to the CAL (calibrate) position.

Set the CH 1 coupling switch on the oscilloscope to the GND (ground) position. Adjust the position of the beam to be at the center of the screen corresponding to the zero y-axis value.

Using the multimeter, set the DC power supply for an output of +5 V. Connect Channel 1 of the oscilloscope to the power supply leads. Set the volts/div for Channel 1 to 5 V/div. Also, set the coupling for Channel 1 to DC. Draw the corresponding waveform which is the output of the DC power supply in the reticle provided below.

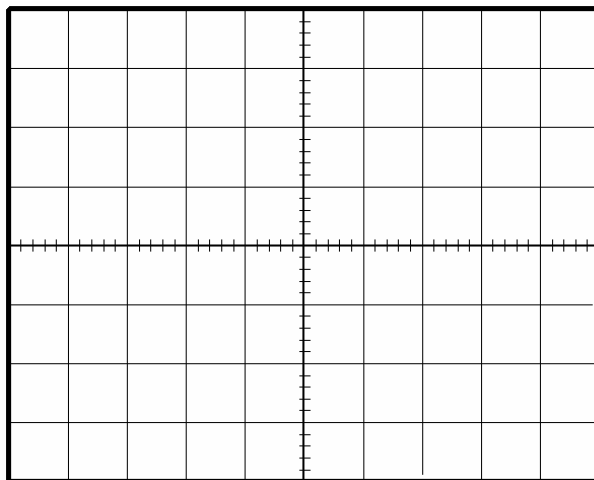


Volts/Div :

Sec/Div :

Does the waveform change when the Channel 1 coupling is switched to AC? If so, how and why?

Set the coupling back to DC. Using the function generator and the scope, apply a sine wave of frequency 2000 Hz, and arbitrary amplitude to the input of the oscilloscope. Adjust the time base on the scope such that approximately two periods are displayed on the scope. Draw the waveform on the reticle provided below.



Volts/Div : _

Sec/Div :

Now, using the voltmeter and the oscilloscope, determine the following:

Peak Amplitude (from Oscilloscope) :

Meter Reading :

Peak Value (calculated from meter reading) :

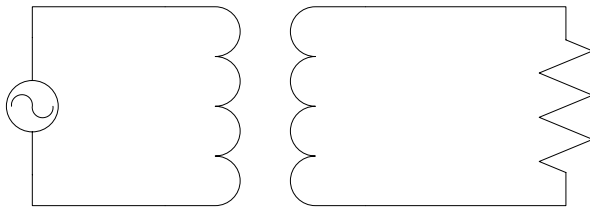
% Difference (Between Oscilloscope and Meter) :

STEP 13**ENERGY TRANSFER PRINCIPLE USING TRANSFORMER****Objective:**

To understand the Energy Transfer Principle Using Transformer.

Required Components and Equipments:

- Low-voltage AC power supply(0-30V)
- Variable resistor(0-10k Ω)
- Transformer
- 3 DMM

Diagram of Circuit:**Theory:**

A transformer is an energy transfer device. It has an input side (primary) and an output side (secondary). Electrical energy applied to the primary is converted to a magnetic field which in turn, induces a current in the secondary which carries energy to the load connected to the secondary. The energy applied to the primary must be in the form of a changing voltage which creates a constantly changing current in the primary, since only a changing magnetic field will produce a current in the secondary.

A transformer consists of at least two sets of windings wound on a single magnetic core. There

are two main purposes for using transformers. The first is to convert the energy on the primary side to a different voltage level on the secondary side. This is accomplished by using differing turns counts on primary and secondary windings. The voltage ratio is the same as the turns ratio. The second purpose is to isolate the energy source from the destination, either for personal safety, or to allow a voltage offset between the source and load.

Transformers are generally divided into two main types. Power transformers are used to convert voltages and provide operating power for electrical devices, while signal transformers are used to transfer some type of useful information from one form or location to another.

Procedure:

Connect the circuit as shown the figure above. Set the variable resistor R_L to 2.5 K Ω and take the measurements. It is advised to measure peak values of input and output voltages then convert them to root mean square values.

V_{in} = _____ volts

I_{in} = _____ mA

P_{in} = _____ Watts

V_{out} = _____ volts

I_{out} = _____ mA

P_{out} = _____ Watts

Can u tell “the primary coil is not connected to secondary coil electrically, Why the current is flowing through the R_L and power is being delivered”



RIMS**EDUCATION****EU, USA and Canada**

Weston Villa, 37 Wolsey Road, Esher, Surrey
United Kingdom KT10 8NT

www.rims-tech.co.uk

Middle East & Asia Pacific

632-B Chakala Scheme-III Rawalpindi
Pakistan 46000

www.rimsedu.com



Product Title: RIMS Advanced Digital Trainer

Document Code: DEV2766-00-321

Revision 2.0.1 dated February 2007

© RIMS 1999-2007. All Rights Reserved. No part of this manual is to be copied, modified or sold in any form without prior permission of RIMS EDUCATION

For any further queries please visit our website at

<http://www.rims-tech.co.uk>