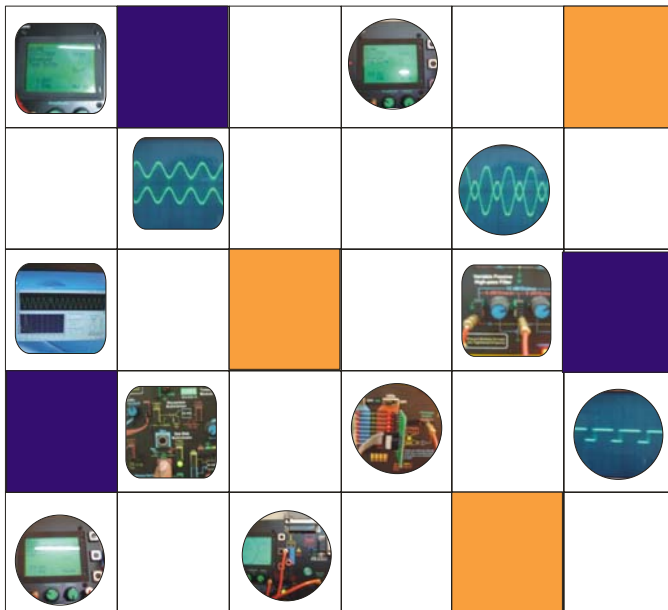

RIMSResearch Instrumentation
& Measurement Systems**DEV-2769****Advanced Electronics Trainer****EXPERIMENTS****Volume 4****PART NO. 2769-00-321**

**COMPREHENSIVE AND ILLUSTRATED
EASY EXPERIMENTS STARTUP
LAB MANUAL**

THANK YOU FOR CHOOSING RIMS EDUCATION PRODUCTS AND SERVICES

Once you have made it through this guide, you will have a firm grip on your lab experiments and operations of the RIMS product you are using. How to get your training equipment operational, basic maintenance and setting up desired experiments will just be a breeze. Everything you need for a quick and easy start is presented here—useful hints and tips makes it simple to conduct your lab and hands-on training sessions. We are happy that you have joined our vast community of over 30 thousand valued users, which grow as we bring you the latest technology at most competitive prices. We value your business and hope that you will enjoy being an important member of the RIMS Education Community.

Customer Support Team



EU, USA and Canada

Weston Villa, 37 Wolsey Road, Esher, Surrey
United Kingdom KT10 8NT
www.rims-tech.co.uk

Middle East & Asia Pacific

632-B Chakala Scheme-III Rawalpindi
Pakistan 46000
www.rimsedu.com

© RIMS 1999-2006. All Rights Reserved. No part of this manual is to be copied, modified or sold in any form without prior permission of RIMS EDUCATION for any further queries please visit our website at <http://www.rims-tech.co.uk>

WARRANTY

The media on which you receive RIMS Technologies software/hardware are warranted for defects in materials and workmanship, for a period of 90 days from date of shipment, as evidenced by receipts or other documentation. RIMS Technologies will, at its option, repair or replace software/hardware media that do not execute programming instructions if RIMS Technologies receives notice of such defects during the warranty period. RIMS Technologies does not warrant that the operation of the software/hardware shall be uninterrupted or error free.

A Return Material Authorization (RMA) number must be obtained from the factory and clearly marked on the outside of the package before any equipment will be accepted for warranty work. RIMS Technologies will pay the shipping costs of returning to the owner parts which are covered by warranty.

RIMS Technologies believes that the information in this document is accurate. The document has been carefully reviewed for technical accuracy. In the event that technical or typographical errors exist, RIMS Technologies reserves the right to make changes to subsequent editions of this document without prior notice to holders of this edition. The reader should consult RIMS Technologies if errors are suspected.

In no event shall RIMS Technologies be liable for any damages arising out of or related to this document or the information contained in it. EXCEPT AS SPECIFIED HEREIN, RIMS TECHNOLOGIES MAKES NO WARRANTIES, EXPRESS OR IMPLIED, AND SPECIFICALLY DISCLAIMS ANY WARRANTY OF MERCHANTABILITY OR FITNESS FOR A PARTICULAR PURPOSE. RIMS TECHNOLOGIES WILL NOT BE LIABLE FOR DAMAGES RESULTING FROM LOSS OF DATA, PROFITS, USE OF PRODUCTS, OR INCIDENTAL OR CONSEQUENTIAL DAMAGES, EVEN IF ADVISED OF THE POSSIBILITY THEREOF. This limitation of the liability of RIMS Technologies will apply regardless of the form of action, whether in contract or tort, including negligence. Any action against RIMS Technologies must be brought within one year after the cause of action accrues. RIMS Technologies shall not be liable for any delay in performance due to causes beyond its reasonable control. The warranty provided herein does not cover damages, defects, malfunctions, or service failures caused by owner's failure to follow the RIMS Technologies installation, operation, or maintenance instructions; owner's modification of the product; owner's abuse, misuse, or negligent acts; and power failure or surges, act of God, fire, flood, accident, actions of third parties, or other events outside reasonable control.

COPYRIGHT

Under the copyright laws, this publication may not be reproduced or transmitted in any form, electronic or mechanical, including photocopying, recording, storing in an information retrieval system, or translating, in whole or in part, without the prior written consent of RIMS Technologies.

TRADEMARKS

RIMS™, ThinPoint™, Power to Sense and Control™, INSPTEP™, LiveLabs™, RIMS Technologies™, BOX™, RIMS-Scope™, StateView™, rims-tech.co.uk™, RIMS-DAQ™, RIMS Students Zone™, and RIMS-Passport™ are trademarks of RIMS Technologies.

Product and company names mentioned herein are trademarks or trade names of rims technologies.

PATENTS

For patents covering RIMS Technologies products, refer to the RIMS Website www.rims-tech.co.uk.

WARNING REGARDING USE OF RIMS TECHNOLOGIES PRODUCTS

(1) RIMS Technologies products are not designed with components and testing for a level of reliability suitable for use in or in connection with surgical implants or as critical components in any life support systems whose failure to perform can reasonably be expected to cause significant injury to a human and also for industrial or specify critical application.

(2) In any application, including the above, reliability of operation of the software/hardware products can be impaired by adverse factors, including but not limited to fluctuations in electrical power supply, computer hardware malfunctions, computer operating system software/hardware fitness, fitness of compilers and development software/hardware used to develop an application, installation errors, software and hardware compatibility problems, malfunctions or failures of electronic monitoring or control devices, transient failures of electronic systems (hardware and/or software), unanticipated uses or misuses, or errors on the part of the user or applications designer (adverse factors such as these are hereafter collectively termed "system failures"). Any application where a system failure would create a risk of harm to property or persons (including the risk of bodily injury and death) should not be reliant solely upon one form of electronic system due to the risk of system failure. To avoid damage, injury, or death, the user or application designer must take reasonably prudent steps to protect against system failures, including but not limited to back-up or shut down mechanisms. Because each end-user system is customized and differs from rims technologies' testing platforms and because a user or application designer may use rims technologies products in combination with other products in a manner not evaluated or contemplated by rims technologies, the user or application designer is ultimately responsible for verifying and validating the suitability of rims technologies products whenever rims technologies products are incorporated in a system or application, including, without limitation, the appropriate design, process and safety level of such system or application.

(3) All efforts have been done to ensure the correctness of the information or media provided explicitly or implicitly for each training system. However RIMS technologies do not take any responsibility for the losses or otherwise any issues arising from the mistake in the media provided. RIMS would strive to ensure that the mistakes are corrected and communicated to all its customers.

General Information

- Understanding RIMS part numbers
- Signals Terminology

© RIMS 1999-2006. All Rights Reserved. No part of this manual is to be copied, modified or sold in any form without prior permission of RIMS EDUCATION
For any further queries please visit our website at
<http://www.rims-tech.co.uk>

1	UNDERSTANDING RIMS PART NUMBERS?
----------	---

Normally the trainer packaging contains the part numbers that you have ordered. You must understand the order number system for checking your packing note or even for later re-ordering of the equipment.

Trainer	-	Prefix	-	Sub-Category
DEV-2769	-	00	-	101

CODE	PF	SUB	Description
DEV-2765			Advanced E
DEV-2765	M	001	Trainer DEV
DEV-2765	00	101	Power Co
DEV-2765	00	331	Softwa
DEV-2765	00	301	Use

Trainer name is the broad category e.g., 2769 is a Advanced Electronics Trainer

The trainer has a prefix that represents the model Number of trainer e.g., 'M' or 'N'

Sub assembly is the hardware component that can be connected to the trainer some modules are compatible with other trainers as well but the part number would only be related to the trainer for which the have been designed

CODE	PF	SUB	Description
DEV-2765			Advanced E
DEV-2765	M	001	Trainer DEV
DEV-2765	00	101	Power Co
DEV-2765	00	331	Softwa
DEV-2765	00	301	Use

Category is most important feature of this numbering. The under lying structure for category is same for all rims products, the category list is given here,

001-100	Hardware ID
101-200	Cables & Accessories
201-300	Special Attachments
301-400	Data Pack and Media
401-500	Services, Freight and Installations
501-600	Extended Warranties

Here are some common sub categories

101-110	Power Cord
111-120	Interconnecting aids & Data buses
121-130	Dust Covers

131-140	Bread boarding accessories
141-150	Specialized Power Cables
151-160	Extensions and boards
161-170	Cables Serial and Parallel
171-180	Specialized Cables
301-310	Operation Manuals and User Guide
321-330	Experiment Manuals
331-350	SOFTWARE
401-410	Services, Freight and Installations
501-510	Extended Warranties

CODE	P	SUB	Description
DEV-2785			Advanced U
DEV-2785	M	001	Trainer DEV
DEV-2785	00	101	Power Ca
DEV-2785	00	331	Softw
DEV-2785	00	301	Use

Please use the appropriate order code for either re-ordering components or the equipment from RIMS. The list is subject to further change without altering the existing structure. Please visit RIMS website for any further details about the updates on support pages.

2**SIGNALS TERMINOLOGY**

Following terms are used for various signals

Frequency

Number of cycles per second

Carrier Signal

Signal that is used as base for carrying signals over long distance usually high frequency signal

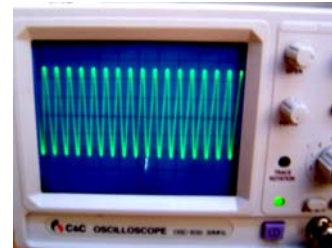

Carrier

Modulating Signal

Signal that is being modulated such as audio or low frequency signal relative to carrier

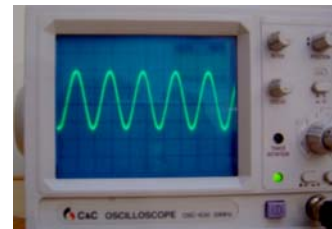

Modulating Signal/ Audio Signal

Modulated Signal

Signal after modulating on the carrier



Modulating Signal

Noise

Uncertainty or randomness in a signal that is represented by sufficient statistics such as mean, variance etc.

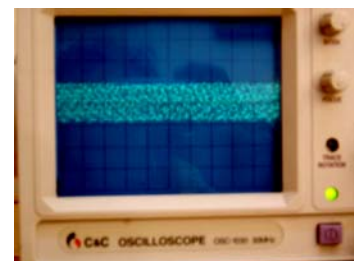

Noise

Clock

TTL or square wave for digital control

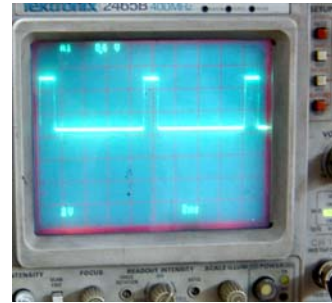

Clock/Pulse

Voltage

A certain level of signal fixed and not varying e.g., 2.3Volts

Drift

Slowly varying noise (undesired signal)

Offset/Bias

DC level in a signal



Offset/DC Level in AC Signal

Keying

Shifting frequencies within discrete levels

Audio Signal

Normally 300-3500Hz for communications application. Audible range is 20-20KHz, but the telephonic bandwidth is one given above. Above 10KHz and below 300Hz is considered as HI-FI (high fidelity)

Sampling Frequency

Rate at which a signal is digitized by a analog to digital converter

Power

Signal for driving the devices and running the system electronic, while other electronics signals are referred to as signal

Welcome to RIMS Advanced Electronics Trainer

List of experiments:

1. Voltage comparator
2. Precision voltage follower
3. Non-inverting amplifier
4. High-impedance voltmeter
5. Integrator

Product Title: EXPERIMENTS

Document Code: DEV2769-00-321

Revision 2.0.0 dated February 2007

© RIMS 1999-2006. All Rights Reserved. No part of this manual is to be copied, modified or sold in any form without prior permission of RIMS EDUCATION for any further queries please visit our website at <http://www.rims-tech.co.uk>

STEP 1**VOLTAGE COMPARATOR****Objective:**

- How to use an op-amp as a comparator

Required Components and Equipments:

- Operational amplifier, model 1458 or 353 recommended
- Three 6 volt batteries
- Two 10 k Ω potentiometers, linear taper
- One light-emitting diode
- One 330 Ω resistor
- One 470 Ω resistor
-

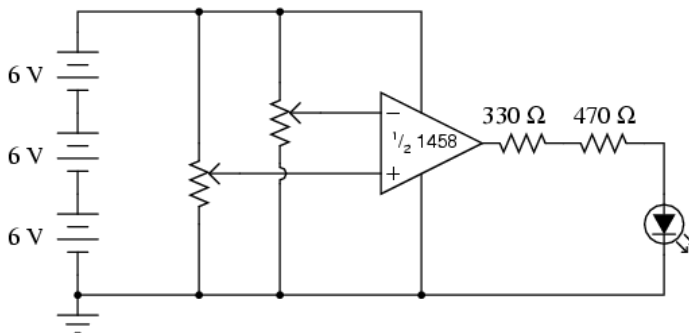
Diagram of Circuit:**Procedure:**

A comparator circuit compares two voltage signals and determines which one is greater. The result of this comparison is indicated by the output voltage: if the op-amp's output is saturated in the positive direction, the non-inverting input (+) is a greater, or more positive, voltage than the inverting input (-), all voltages measured with respect to ground. If the op-amp's voltage is near the negative supply voltage

(in this case, 0 volts, or ground potential), it means the inverting input (-) has a greater voltage applied to it than the non-inverting input (+).

This behavior is much easier understood by experimenting with a comparator circuit than it is by reading someone's verbal description of it. In this experiment, two potentiometers supply variable voltages to be compared by the op-amp. The output status of the op-amp is indicated visually by the LED. By adjusting the two potentiometers and observing the LED, one can easily comprehend the function of a comparator circuit.

For greater insight into this circuit's operation, you might want to connect a pair of voltmeters to the op-amp input terminals (both voltmeters referenced to ground) so that both input voltages may be numerically compared with each other, these meter indications compared to the LED status:

STEP 2

PRECISION VOLTAGE FOLLOWER

Objective:

- How to use an op-amp as a voltage follower
- Purpose of negative feedback
- Troubleshooting strategy

Required Components and Equipments:

- Operational amplifier, model 1458 or 353 recommended
- Three 6 volt batteries
- One 10 k Ω potentiometer, linear taper

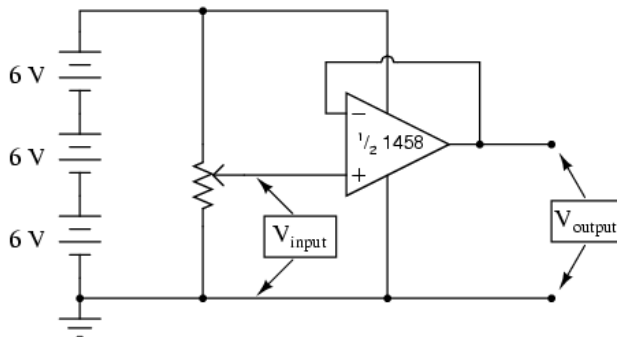
Diagram of Circuit:**Procedure:**

In the previous op-amp experiment, the amplifier was used in "open-loop" mode; that is, without any *feedback* from output to input. As such, the full voltage gain of the operational amplifier was available, resulting in the output voltage saturating for virtually any amount of differential voltage applied between the two input terminals. This is good if we desire comparator operation, but if we want the op-amp to behave as a true *amplifier*, we

need it to exhibit a manageable voltage gain. Since we do not have the luxury of disassembling the integrated circuitry of the op-amp and changing resistor values to give a lesser voltage gain, we are limited to external connections and componentry. Actually, this is not a disadvantage as one might think, because the combination of extremely high open-loop voltage gain coupled with feedback allows us to use the op-amp for a much wider variety of purposes, much easier than if we were to exercise the option of modifying its internal circuitry. If we connect the output of an op-amp to its inverting (-) input, the output voltage will seek whatever level is necessary to balance the inverting input's voltage with that applied to the non-inverting (+) input. If this feedback connection is direct, as in a straight piece of wire, the output voltage will precisely "follow" the non-inverting input's voltage. Unlike the *voltage follower* circuit made from a single transistor (see chapter 5: Discrete Semiconductor Circuits), which approximated the input voltage to within several tenths of a volt, this voltage follower circuit will output a voltage accurate to within mere *microvolts* of the input voltage! Measure the input voltage of this circuit with a voltmeter connected between the op-amp's non-inverting (+) input terminal and circuit ground (the negative side of the power supply), and the output voltage between the op-amp's output terminal and circuit ground. Watch the op-amp's output voltage follow the input voltage as you adjust the potentiometer through its range. You may directly measure the difference, or *error*, between output and input voltages by connecting the voltmeter between the op-amp's two input terminals. Throughout most of the potentiometer's range, this error voltage should be almost zero. Try moving the potentiometer to one of its extreme positions, far clockwise or far counterclockwise.

Measure error voltage, or compare output voltage against input voltage. Do you notice anything unusual? If you are using the model 1458 or model 353 op-amps for this experiment, you should measure a substantial error voltage, or difference between output and input. Many op-amps, the specified models included, cannot "swing" their output voltage exactly to full power supply ("rail") voltage levels. In this case, the "rail" voltages are +18 volts and 0 volts, respectively. Due to limitations in the 1458's internal circuitry, its output voltage is unable to exactly reach these high and low limits. You may find that it can only go within a volt or two of the power supply "rails." This is a very important limitation to understand when designing circuits using operational amplifiers. If full "rail-to-rail" output voltage swing is required in a circuit design, other op-amp models may be selected which offer this capability. The model 3130 is one such op-amp.

Precision voltage follower circuits are useful if the voltage signal to be amplified cannot tolerate "loading;" that is, if it has a high source impedance. Since a voltage follower by definition has a voltage gain of 1, its purpose has nothing to do with amplifying voltage, but rather with amplifying a signal's capacity to deliver *current* to a load.

Voltage follower circuits have another important use for circuit builders: they allow for simple linear testing of an op-amp. One of the troubleshooting techniques I recommend is to *simplify and rebuild*. Suppose that you are building a circuit using one or more op-amps to perform some advanced function. If one of those op-amps seems to be causing a problem and you suspect it may be faulty, try re-connecting it as a simple voltage follower and see if it functions in that capacity. An op-amp that fails to work as a voltage follower certainly won't work as anything more complex!

STEP 3**NON-INVERTING AMPLIFIER****Objective:**

- How to use an op-amp as a single-ended amplifier
- Using divided, negative feedback

Required Components and Equipments:

- Operational amplifier, model 1458 or 353 recommended
- Three 6 volt batteries
- Two 10 k Ω potentiometers, linear taper

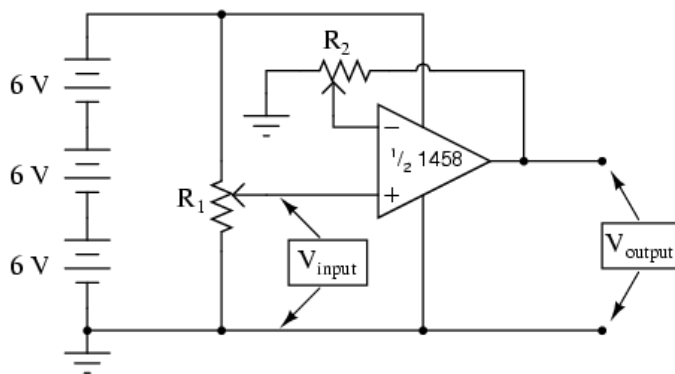
Diagram of Circuit:**Procedure:**

This circuit differs from the voltage follower in only one respect: output voltage is "fed back" to the inverting (-) input through a voltage-dividing potentiometer rather than being directly connected. With only a *fraction* of the output voltage fed back to the inverting input, the op-amp will output a corresponding *multiple* of the voltage sensed at the non-inverting (+) input in keeping the input differential voltage near zero. In other words, the

op-amp will now function as an amplifier with a controllable voltage gain, that gain being established by the position of the feedback potentiometer (R_2).

Set R_2 to approximately mid-position. This should give a voltage gain of about 2. Measure both input and output voltage for several positions of the input potentiometer R_1 . Move R_2 to a different position and re-take voltage measurements for several positions of R_1 . For any given R_2 position, the ratio between output and input voltage should be the same.

You will also notice that the input and output voltages are always positive with respect to ground. Because the output voltage increases in a positive direction for a positive increase of the input voltage, this amplifier is referred to as *non-inverting*. If the output and input voltages were related to one another in an inverse fashion (i.e. positive increasing input voltage results in positive decreasing or negative increasing output), then the amplifier would be known as an *inverting* type.

The ability to leverage an op-amp in this fashion to create an amplifier with controllable voltage gain makes this circuit an extremely useful one. It would take quite a bit more design and troubleshooting effort to produce a similar circuit using discrete transistors.

STEP 4	HIGH-IMPEDANCE VOLTMETER
---------------	---------------------------------

Objective:

- Voltmeter loading: its causes and its solution
- How to make a high-impedance voltmeter using an op-amp
- What op-amp "latch-up" is and how to avoid it

Required Components and Equipments:

- Operational amplifier, model TL082 recommended
- Operational amplifier, model LM1458 recommended
- Four 6 volt batteries
- One Amperes meter, 1 mA full-scale deflection
- 15 k Ω precision resistor
- Four 1 M Ω resistors

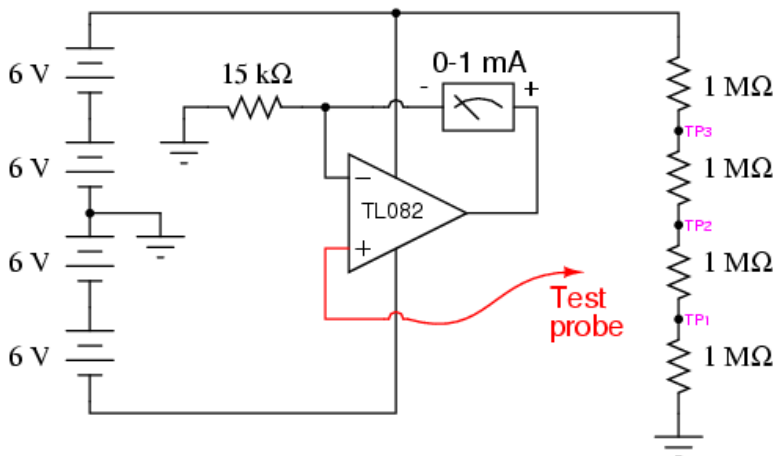
Diagram of Circuit:**Procedure:**

An ideal voltmeter has infinite input impedance, meaning that it draws zero current from the circuit

under test. This way, there will be no "impact" on the circuit as the voltage is being measured. The more current a voltmeter draws from the circuit under test, the more the measured voltage will "sag" under the loading effect of the meter, like a tire-pressure gauge releasing air out of the tire being measured: the more air released from the tire, the more the tire's pressure will be impacted in the act of measurement. This loading is more pronounced on circuits of high resistance, like the voltage divider made of $1\text{ M}\Omega$ resistors, shown in the schematic diagram.

If you were to build a simple 0-15 volt range voltmeter by connecting the 1 mA meter movement in series with the $15\text{ k}\Omega$ precision resistor, and try to use this voltmeter to measure the voltages at TP1, TP2, or TP3 (with respect to ground), you'd encounter severe measurement errors induced by meter "impact:"

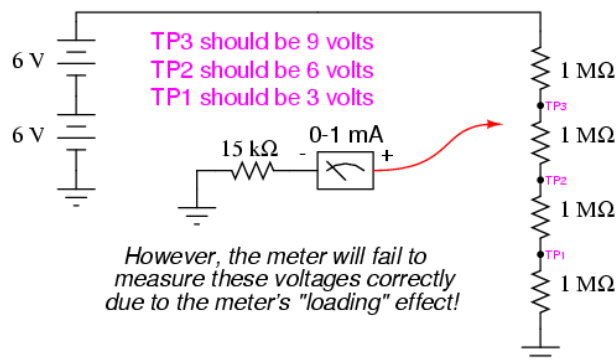

Try using the meter movement and $15\text{ k}\Omega$ resistor as shown to measure these three voltages. Does the meter read falsely high or falsely low? Why do you think this is?

If we were to increase the meter's input impedance, we would diminish its current draw or "load" on the circuit under test and consequently improve its measurement accuracy. An op-amp with high-impedance inputs (using a JFET transistor input

stage rather than a BJT input stage) works well for this application.

Note that the meter movement is part of the op-amp's feedback loop from output to inverting input. This circuit drives the meter movement with a current proportional to the voltage impressed at the noninverting (+) input, the requisite current supplied directly from the batteries through the op-amp's power supply pins, not from the circuit under test through the test probe. The meter's range is set by the resistor connecting the inverting (-) input to ground.

Build the op-amp meter circuit as shown and re-take voltage measurements at TP1, TP2, and TP3. You should enjoy far better success this time, with the meter movement accurately measuring these voltages (approximately 3, 6, and 9 volts, respectively).

You may witness the extreme sensitivity of this voltmeter by touching the test probe with one hand and the most positive battery terminal with the other. Notice how you can drive the needle upward on the scale simply by measuring battery voltage through your body resistance: an impossible feat with the original, unamplified voltmeter circuit. If you touch the test probe to ground, the meter should read exactly 0 volts.

After you've proven this circuit to work, modify it by changing the power supply from dual to split. This entails removing the center-tap ground connection between the 2nd and 3rd batteries, and grounding the far negative battery terminal instead:

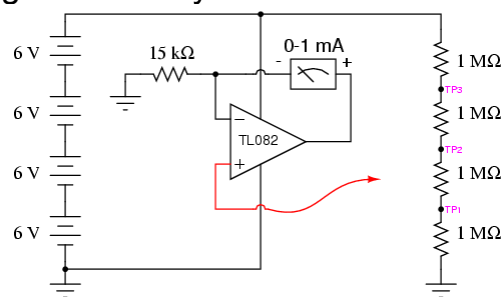

This alteration in the power supply increases the voltages at TP1, TP2, and TP3 to 6, 12, and 18 volts, respectively. With a 15 k Ω range resistor and a 1 mA meter movement, measuring 18 volts will gently "peg" the meter, but you should be able to measure the 6 and 12 volt test points just fine. Try touching the meter's test probe to ground. This *should* drive the meter needle to exactly 0 volts as before, but it will not! What is happening here is an op-amp phenomenon called *latch-up*: where the op-amp output drives to a positive voltage when the input common-mode voltage exceeds the allowable limit. In this case, as with many JFET-input op-amps, neither input should be allowed to come close to either power supply rail voltage. With a single supply, the op-amp's negative power rail is at ground potential (0 volts), so grounding the test probe brings the non-inverting (+) input exactly to that rail voltage. This is bad for a JFET op-amp, and drives the output strongly positive, even though it doesn't seem like it should, based on how op-amps are supposed to function.

When the op-amp ran on a "dual" supply (+12/-12 volts, rather than a "single" +24 volt supply), the negative power supply rail was 12 volts away from ground (0 volts), so grounding the test probe didn't violate the op-amp's common-mode voltage limit. However, with the "single" +24 volt supply, we have a problem. Note that some op-amps do not "latch-up" the way the model TL082 does. You may replace the TL082 with an LM1458 op-amp, which is pin-for-pin compatible (no breadboard wiring changes needed). The model 1458 will not "latch-up" when the test probe is grounded, although you may still get incorrect meter readings with the measured voltage exactly equal to the negative power supply rail. As a general rule, you should always be sure the op-amp's power supply rail voltages exceed the expected input voltages.

STEP 5 INTEGRATOR**Objective:**

- Method for limiting the span of a potentiometer
- Purpose of an integrator circuit
- How to compensate for op-amp bias current

Required Components and Equipments:

- Four 6 volt batteries
- Operational amplifier, model 1458 recommended
- One 10 k Ω potentiometer, linear taper
- Two capacitors, 0.1 μ F each, non-polarized
- Two 100 k Ω resistors
- Three 1 M Ω resistors

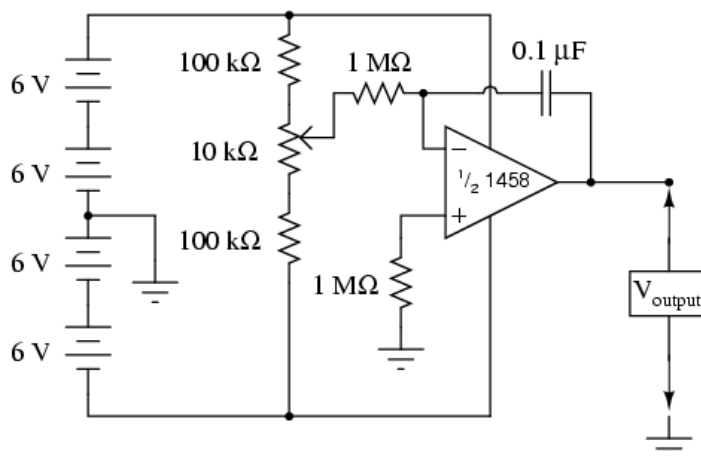
Diagram of Circuit:

Procedure:

As you can see from the schematic diagram, the potentiometer is connected to the "rails" of the power source through 100 k Ω resistors, one on each end. This is to limit the span of the potentiometer, so that full movement produces a fairly small range of input voltages for the op-amp to operate on. At one extreme of the potentiometer's motion, a voltage of about 0.5 volt (with respect to the ground point in the middle of the series battery string) will be produced at the potentiometer wiper. At the other extreme of motion, a voltage of about -0.5 volt will be produced. When the potentiometer is positioned dead-center, the wiper voltage should measure zero volts.

Connect a voltmeter between the op-amp's output terminal and the circuit ground point. Slowly move the potentiometer control while monitoring the output voltage. The output voltage should be *changing* at a rate established by the potentiometer's deviation from zero (center) position. To use calculus terms, we would say that the output voltage represents the *integral* (with respect to time) of the input voltage function. That is, the input voltage level establishes the output voltage *rate of change over time*. This is precisely the opposite of *differentiation*, where the *derivative* of a signal or function is its instantaneous rate of change.

If you have two voltmeters, you may readily see this relationship between input voltage and output *voltage rate of change* by measuring the wiper voltage (between the potentiometer wiper and ground) with one meter and the output voltage (between the op-amp output terminal and ground) with the other. Adjusting the potentiometer to give zero volts should result in the slowest output voltage rate-of-change. Conversely, the more voltage input to this circuit, the faster its output

voltage will change, or "ramp."

Try connecting the second $0.1 \mu\text{F}$ capacitor in parallel with the first. This will double the amount of capacitance in the op-amp's feedback loop. What affect does this have on the circuit's integration rate for any given potentiometer position?

Try connecting another $1 \text{ M}\Omega$ resistor in parallel with the input resistor (the resistor connecting the potentiometer wiper to the inverting terminal of the op-amp). This will halve the integrator's input resistance. What affect does this have on the circuit's integration rate?

Integrator circuits are one of the fundamental "building-block" functions of an analog computer. By connecting integrator circuits with amplifiers, summers, and potentiometers (dividers), almost any differential equation could be modeled, and solutions obtained by measuring voltages produced at various points in the network of circuits. Because differential equations describe so many physical processes, analog computers are useful as simulators. Before the advent of modern digital computers, engineers used analog computers to simulate such processes as machinery vibration, rocket trajectory, and control system response. Even though analog computers are considered obsolete by modern standards, their constituent components still work well as learning tools for calculus concepts.

Move the potentiometer until the op-amp's output voltage is as close to zero as you can get it, and moving as slowly as you can make it. Disconnect the integrator input from the potentiometer wiper terminal and connect it instead to ground, like this:

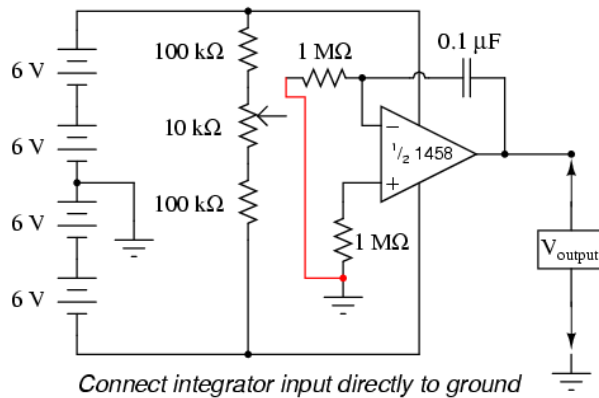

Applying exactly zero voltage to the input of an integrator circuit should, ideally, cause the output voltage rate-of-change to be zero. When you make this change to the circuit, you should notice the output voltage remaining at a constant level or changing very slowly.

With the integrator input still shorted to ground, short past the $1\text{ M}\Omega$ resistor connecting the op-amp's non-inverting (+) input to ground. There should be no need for this resistor in an ideal op-amp circuit, so by shorting past it we will see what function it provides in this very real op-amp circuit:

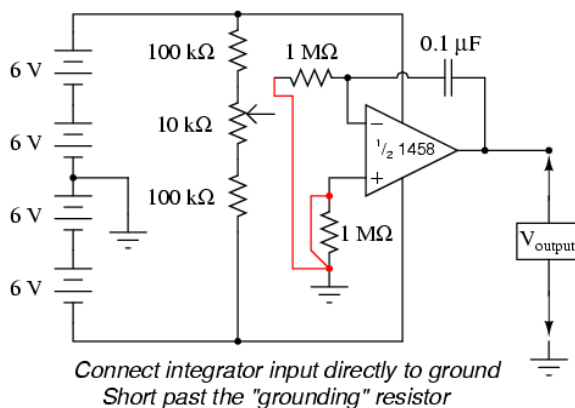

As soon as the "grounding" resistor is shorted with a jumper wire, the op-amp's output voltage will start to change, or drift. Ideally, this should not happen,

because the integrator circuit still has an input signal of zero volts. However, real operational amplifiers have a very small amount of current entering each input terminal called the bias current. These bias currents will drop voltage across any resistance in their path. Since the $1\text{ M}\Omega$ input resistor conducts some amount of bias current regardless of input signal magnitude, it will drop voltage across its terminals due to bias current, thus "offsetting" the amount of signal voltage seen at the inverting terminal of the op-amp. If the other (non-inverting) input is connected directly to ground as we have done here, this "offset" voltage incurred by voltage drop generated by bias current will cause the integrator circuit to slowly "integrate" as though it were receiving a very small input signal.

The "grounding" resistor is better known as a compensating resistor, because it acts to compensate for voltage errors created by bias current. Since the bias currents through each op-amp input terminal are approximately equal to each other, an equal amount of resistance placed in the path of each bias current will produce approximately the same voltage drop. Equal voltage drops seen at the complementary inputs of an op-amp cancel each other out, thus null the error otherwise induced by bias current.

Remove the jumper wire shorting past the compensating resistor and notice how the op-amp output returns to a relatively stable state. It may still drift some, most likely due to bias voltage error in the op-amp itself, but that is another subject altogether!



RIMS**EDUCATION****EU, USA and Canada**

Weston Villa, 37 Wolsey Road, Esher, Surrey
United Kingdom KT10 8NT
www.rims-tech.co.uk

Middle East & Asia Pacific

632-B Chakala Scheme-III Rawalpindi
Pakistan 46000
www.rimsedu.com



DEV-2769-00-321

Product Title: RIMS Advanced Electronics Trainer
Document Code: DEV2769-00-321
Revision 2.0.1 dated February 2007
© RIMS 1999-2006. All Rights Reserved. No part of this
manual is to be copied, modified or sold in any form without
prior permission of RIMS EDUCATION
For any further queries please visit our website at
<http://www.rims-tech.co.uk>